



SSCS521S30D3

Schottky Barrier Diode

● Features

- ◇ Small surface mounting type
- ◇ Low reverse current and low forward voltage
- ◇ High reliability

● PIN configuration

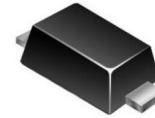

SOD-523



Circuit Diagram

● Applications

- ◇ High speed switching for detection
- ◇ For portable equipment:(i.e. Mobile phone,MP3, MD,CD-ROM,DVD-ROM, Note book PC, etc.)



Marking(Top View)

● Absolute maximum rating @T_A=25°C

Parameter	Symbol	Value	Unit
Reverse Voltage(DC)	V _R	30	V
Average Rectified Forward Current	I _o	200	mA
Peak Forward Surge Current	I _{FSM}	1	A
Operating Temperature	T _J	125	°C
Storage Temperature	T _{STG}	-40 ~ +125	°C

● Electrical Characteristics @T_A=25°C

Parameter	Symbol	Conditions	Min.	Typ.	Max.	Unit
Forward Voltage	V _F	I _F = 200mA			0.5	V
Reverse Current	I _R	V _R = 10V			30	uA



- Typical Performance Characteristics

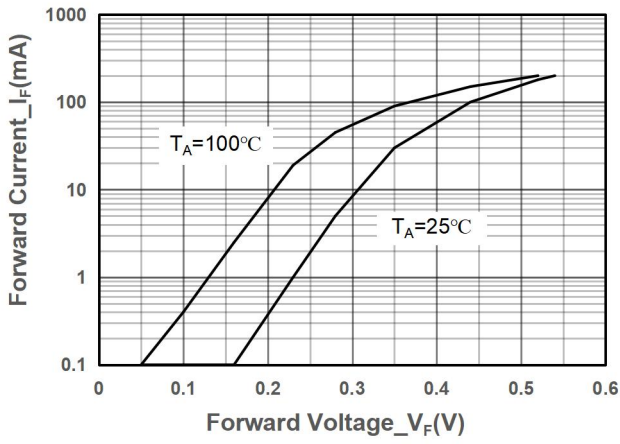

Forward Voltage vs. Forward Current

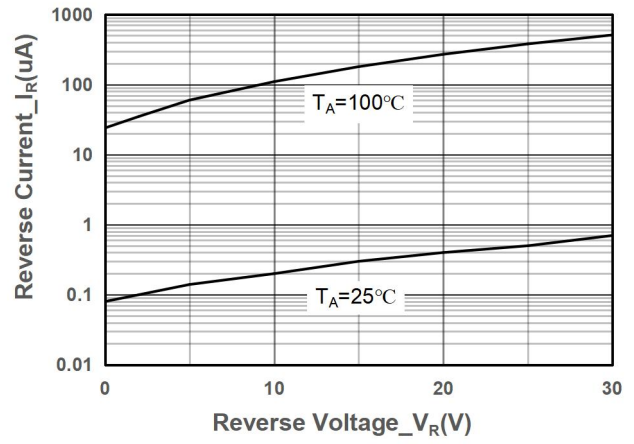

Reverse Voltage vs. Reverse Current



● Package Information

Ordering Information

Device	Package	Marking	Qty per Reel	Reel Size
SSCS521S30D3	SOD-523	C	3000	7 Inch

Mechanical Data

Case: SOD-523

Case Material: Molded Plastic. UL Flammability

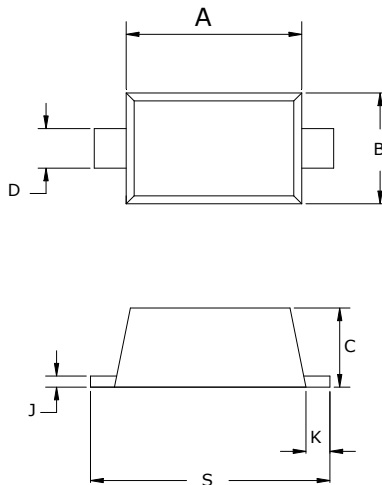

DIM	Millimeters	
	Min	Max
A	1.10	1.30
B	0.75	0.85
C	0.51	0.70
D	0.25	0.35
J	0.08	0.15
K	0.15	0.25
S	1.50	1.70

Recommended Pad outline

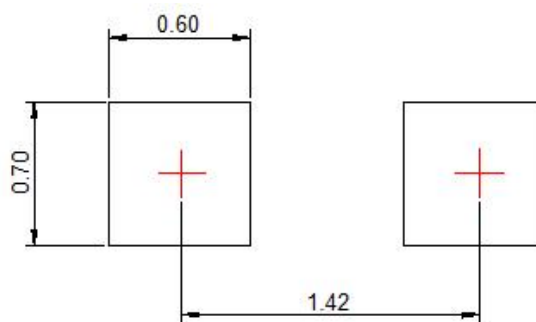



DISCLAIMER

SSCSEMI RESERVES THE RIGHT TO MAKE CHANGES WITHOUT FURTHER NOTICE TO ANY PRODUCTS HEREIN TO IMPROVE RELIABILITY, FUNCTION OR DESIGN. SSCSEMI DOES NOT ASSUME ANY LIABILITY ARISING OUT OF THE APPLICATION OR USE OF ANY PRODUCT OR CIRCUIT DESCRIBED HEREIN; NEITHER DOES IT CONVEY ANY LICIENCE UNDER ITS PATENT RIGHTS, NOR THE RIGHTS OF OTHERS.

THE GRAPHS PROVIDED IN THIS DOCUMENT ARE STATISTICAL SUMMARIES BASED ON A LIMITED NUMBER OF SAMPLES AND ARE PROVIDED FOR INFORMATIONAL PURPOSE ONLY. THE PERFORMANCE CHARACTERISTICS LISTED IN THEM ARE NOT TESTED OR GUARANTEED. IN SOME GRAPHS, THE DATA PRESENTED MAY BE OUTSIDE THE SPECIFIED OPERATING RANGE (E.G. OUTSIDE SPECIFIED POWER SUPPLY RANGE) AND THEREFORE OUTSIDE THE WARRANTED RANGE.

OUR PRODUCT SPECIFICATIONS ARE ONLY VALID IF OBTAINED THROUGH THE COMPANY'S OFFICIAL WEBSITE, CRM SYSTEM, OR OUR SALES PERSONNEL CHANNELS. IF CHANGES OR SPECIAL VERSIONS ARE INVOLVED, THEY MUST BE STAMPED WITH A QUALITY SEAL AND MARKED WITH A SPECIAL VERSION NUMBER TO BE VALID.