



SSCS160M30D1

Schottky Barrier Diode

● Features

- ✧ Low Forward Voltage Drop (VF)
- ✧ Better Efficiency and Low Power Losses,
- ✧ Guard Ring Construction for Transient Protection

● PIN configuration



SOD-123

● Applications

- ✧ Low Voltage Rectification
- ✧ High-Efficiency DC-DC Conversion
- ✧ Switch Mode Power Supply
- ✧ Inverse Polarity Protection



Circuit Diagram



Marking(Top View)

● Absolute maximum rating @T_A=25°C

Parameter	Symbol	Value	Unit
Reverse Voltage (Repetitive Peak)	V _{RRM}	30	V
DC Reverse Voltage	V _R		
Reverse Voltage	V _{R(RMS)}	24	V
Average Rectified Output Current	I _o	1	A
Non-repetitive Peak Forward Surge Current @t=8.3ms	I _{FSM}	15	A
Power Dissipation	P _D	350	mW
Thermal Resistance Junction to Ambient(Typ)	R _{θJA}	170	°C/W
Operating Temperature	T _J	-55 ~ +125	°C
Storage Temperature	T _{STG}	-40 ~ +125	°C

● Electrical Characteristics @T_A=25°C

Parameter	Symbol	Conditions	Min.	Typ.	Max.	Unit
Reverse Breakdown Voltage	V _{BR}	I _R = 250uA	30			V
Forward Voltage	V _F	I _F = 0.5A		0.38	0.45	V
		I _F = 1A		0.43	0.48	
Reverse Leakage Current	I _R	V _R = 15V		2	20	uA
		V _R = 30V		5	50	uA
Junction Capacitance	C _J	V _R =4V,f=1MHz		50		pF



- Typical Performance Characteristics

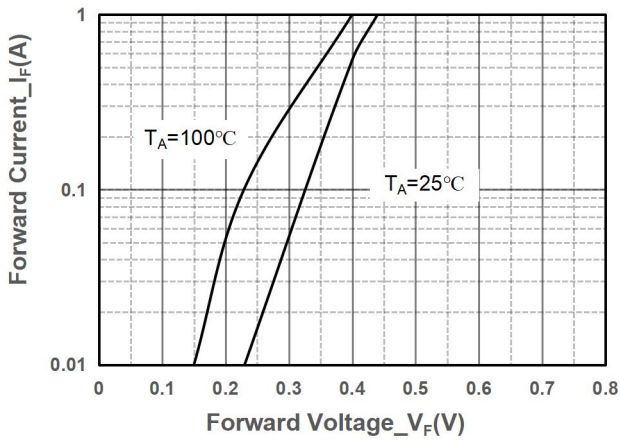

Forward Voltage vs. Forward Current

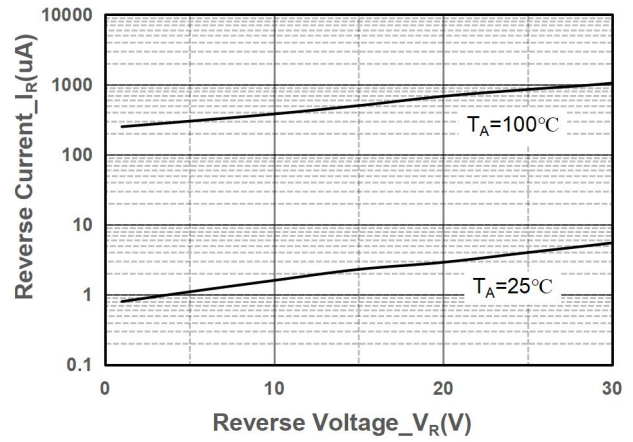

Reverse Voltage vs. Reverse Current

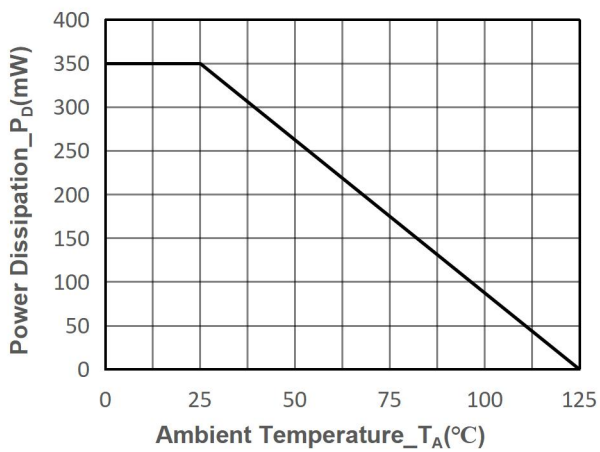

Power Derating vs. Ambient Temperature

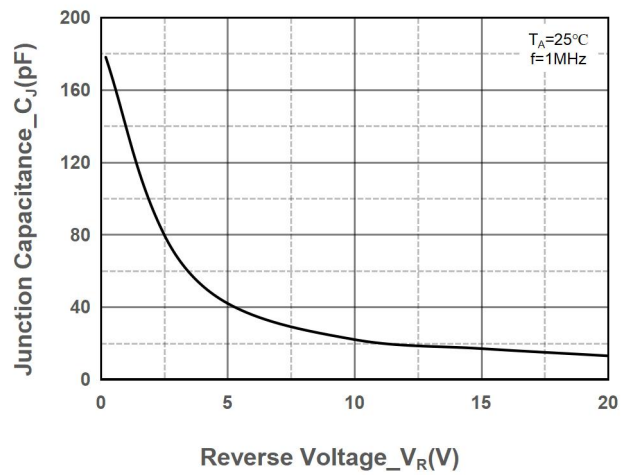

Junction Capacitance vs. Reverse Voltage



● Package Information

Ordering Information

Device	Package	Marking	Qty per Reel	Reel Size
SSCS160M30D1	SOD-123	73	3000	7 Inch

Mechanical Data

Case: SOD-123

Case Material: Molded Plastic. UL Flammability

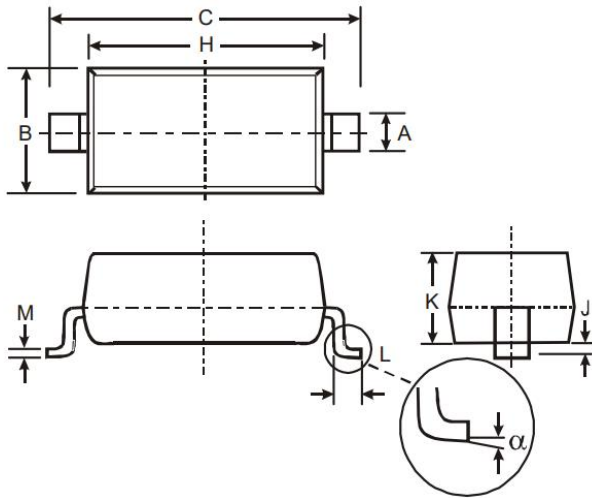

DIM	Millimeters	
	Min	Max
A	0.45	0.65
B	1.50	1.70
C	3.55	3.85
H	2.6	2.8
J	0.00	0.10
K	1.05	1.15
L	0.25	0.45
M	0.08	0.15
α	0	8°

Recommended Pad outline (Unit:mm)

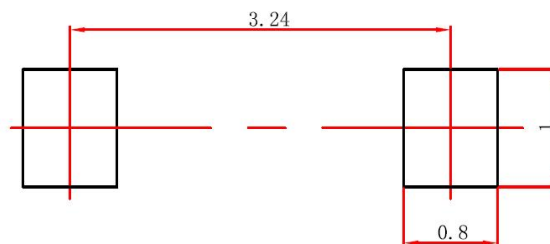



DISCLAIMER

SSCSEMI RESERVES THE RIGHT TO MAKE CHANGES WITHOUT FURTHER NOTICE TO ANY PRODUCTS HEREIN TO IMPROVE RELIABILITY, FUNCTION OR DESIGN. SSCSEMI DOES NOT ASSUME ANY LIABILITY ARISING OUT OF THE APPLICATION OR USE OF ANY PRODUCT OR CIRCUIT DESCRIBED HEREIN; NEITHER DOES IT CONVEY ANY LICIENCE UNDER ITS PATENT RIGHTS, NOR THE RIGHTS OF OTHERS.

THE GRAPHS PROVIDED IN THIS DOCUMENT ARE STATISTICAL SUMMARIES BASED ON A LIMITED NUMBER OF SAMPLES AND ARE PROVIDED FOR INFORMATIONAL PURPOSE ONLY. THE PERFORMANCE CHARACTERISTICS LISTED IN THEM ARE NOT TESTED OR GUARANTEED. IN SOME GRAPHS, THE DATA PRESENTED MAY BE OUTSIDE THE SPECIFIED OPERATING RANGE (E.G., OUTSIDE SPECIFIED POWER SUPPLY RANGE) AND THEREFORE OUTSIDE THE WARRANTED RANGE.

OUR PRODUCT SPECIFICATIONS ARE ONLY VALID IF OBTAINED THROUGH THE COMPANY'S OFFICIAL WEBSITE, CRM SYSTEM, OR OUR SALES PERSONNEL CHANNELS. IF CHANGES OR SPECIAL VERSIONS ARE INVOLVED, THEY MUST BE STAMPED WITH A QUALITY SEAL AND MARKED WITH A SPECIAL VERSION NUMBER TO BE VALID.