



SSC8336GS1

Dual N-Channel Enhancement Mode MOSFET

➤ Features

VDS	VGS	RDS(on) Typ.	ID
30V	±20V	16mR@10V	9A
		20mR@4V5	

➤ Description

This device is produced with high cell density, DMOS trench technology, which is especially used to minimize on-state resistance. This device is particularly suited for low voltage power management requiring a wide range of given voltage ratings(4.5V~25V) such as load switch and battery protection.

➤ Applications

- Li Battery
- Battery charge
- Load Switch

➤ Ordering Information

Device	Package	Shipping
SSC8336GS1	SOP-8	2500/Reel

➤ Pin configuration

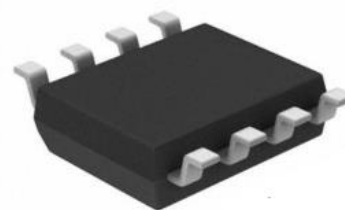
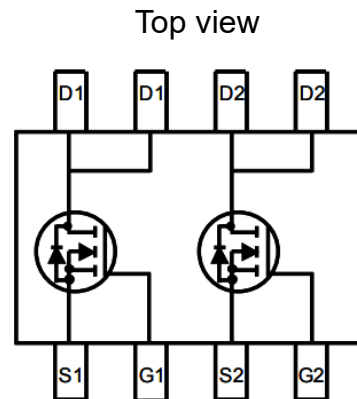

Bottom View

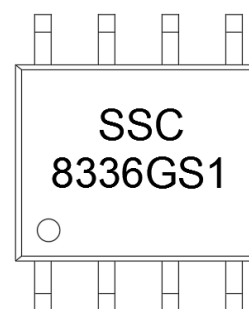

Marking



➤ **Absolute Maximum Ratings**($T_A=25^{\circ}\text{C}$ unless otherwise noted)

Symbol	Parameter	Ratings	Unit
V_{DSS}	Drain-to-Source Voltage	30	V
V_{GSS}	Gate-to-Source Voltage	± 20	V
I_D	Continuous Drain Current ^a	9	A
I_{DM}	Pulsed Drain Current ^b	36	A
P_D	Power Dissipation ^c	3.8	W
P_{DSM}	Power Dissipation ^a	1.5	W
T_J	Operation junction temperature	-55 to 150	$^{\circ}\text{C}$
T_{STG}	Storage temperature range	-55 to 150	$^{\circ}\text{C}$

➤ **Thermal Resistance Ratings**($T_A=25^{\circ}\text{C}$ unless otherwise noted)

Symbol	Parameter	Typical	Maximum	Unit
$R_{\theta JA}$	Junction-to-Ambient Thermal Resistance ^a		100	$^{\circ}\text{C}/\text{W}$
$R_{\theta JC}$	Junction-to-Case Thermal Resistance		40	

Note:

- The value of $R_{\theta JA}$ is measured with the device mounted on 1 in² FR-4 board with 2oz.copper,in a still air environment with $T_A=25^{\circ}\text{C}$.The value in any given application depends on the user is specific board design. The current rating is based on the $t \leq 10\text{s}$ thermal resistance rating.
- Repetitive rating, pulse width limited by junction temperature.
- The power dissipation P_D is based on $T_J(\text{MAX})=150^{\circ}\text{C}$, using junction-to-case thermal resistance, and is more useful in setting the upper dissipation limit for cases where additional heat sinking is used.



➤ **Electronics Characteristics**($T_A=25^{\circ}\text{C}$ unless otherwise noted)

Symbol	Parameter	Test Conditions	Min	Typ.	Max	Unit
$V_{(BR)DSS}$	Drain-Source Breakdown Voltage	$V_{GS}=0V, I_D=250\mu A$	30			V
$V_{GS(th)}$	Gate Threshold Voltage	$V_{DS}=V_{GS}, I_D=250\mu A$	1.1	1.5	2.1	V
$R_{DS(on)}$	Drain-Source On- Resistance	$V_{GS}=10V, I_D=6.9A$		16	20	mR
		$V_{GS}=4.5V, I_D=5.8A$		20	26	
I_{DSS}	Zero Gate Voltage Drain Current	$V_{DS}=24V, V_{GS}=0V$			1	μA
I_{GSS}	Gate-Source leak current	$V_{GS}=\pm 20V, V_{DS}=0V$			± 100	nA
V_{SD}	Forward Voltage	$V_{GS}=0V, I_S=1.7A$		0.8	1	V
G_{FS}	Transconductance	$V_{DS}=10V, I_D=6A$		30		S
C_{iss}	Input Capacitance	$V_{DS}=15V, V_{GS}=0V, f=1MHz$		570		pF
C_{oss}	Output Capacitance			113		
C_{rss}	Reverse Transfer Capacitance			57		
$T_{D(ON)}$	Turn-on delay time	$V_{GS}=10V,$ $V_{DS}=15V,$ $R_L=2.3R, R_G=3R, I_D=5A$		8		ns
T_r	Rise time			5		
$T_{D(OFF)}$	Turn-off delay time			25		
T_f	Fall time			7		
Q_g	Total Gate charge	$V_{GS}=4.5V, V_{DS}=15V,$ $I_D=3A$		7.3		nC
Q_{gs}	Gate to Source charge			2.6		
Q_{gd}	Gate to Drain charge			3		



➤ **Typical Characteristics** ($T_A=25^\circ\text{C}$ unless otherwise noted)

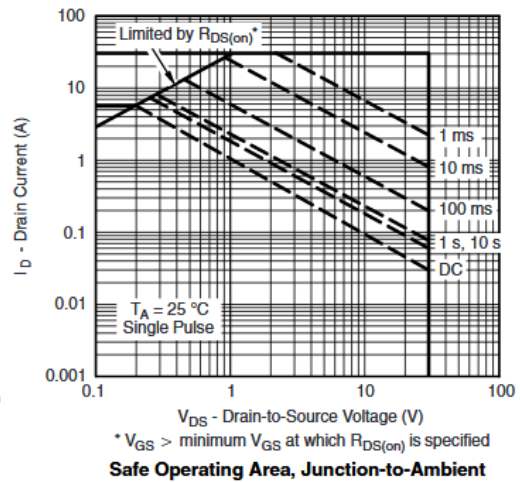
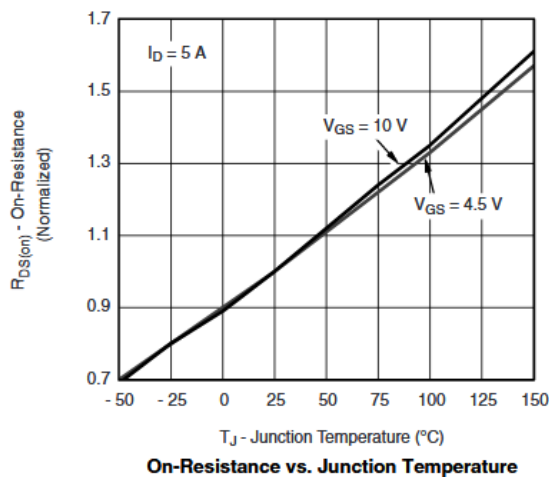
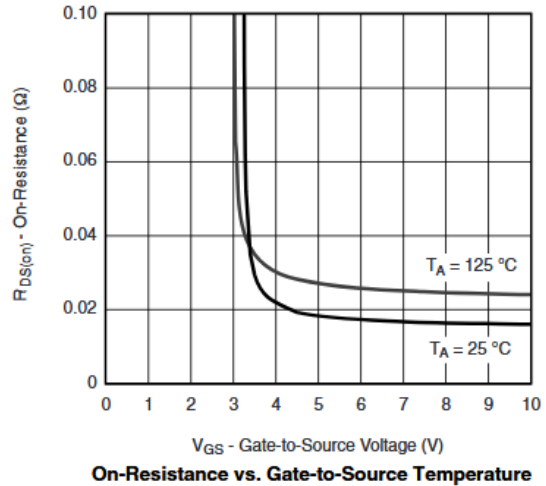
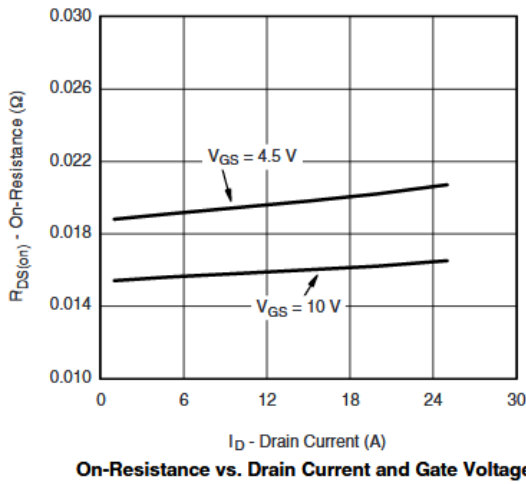
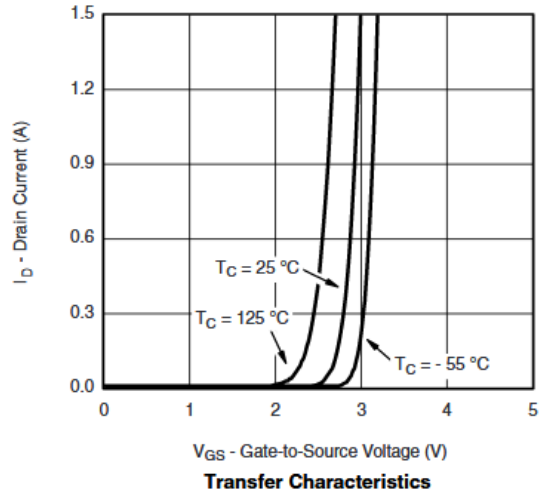
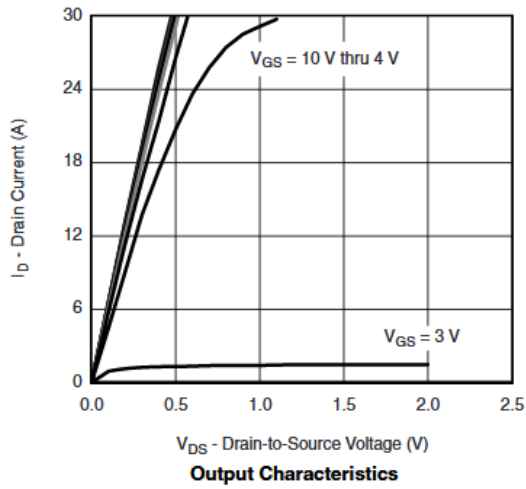

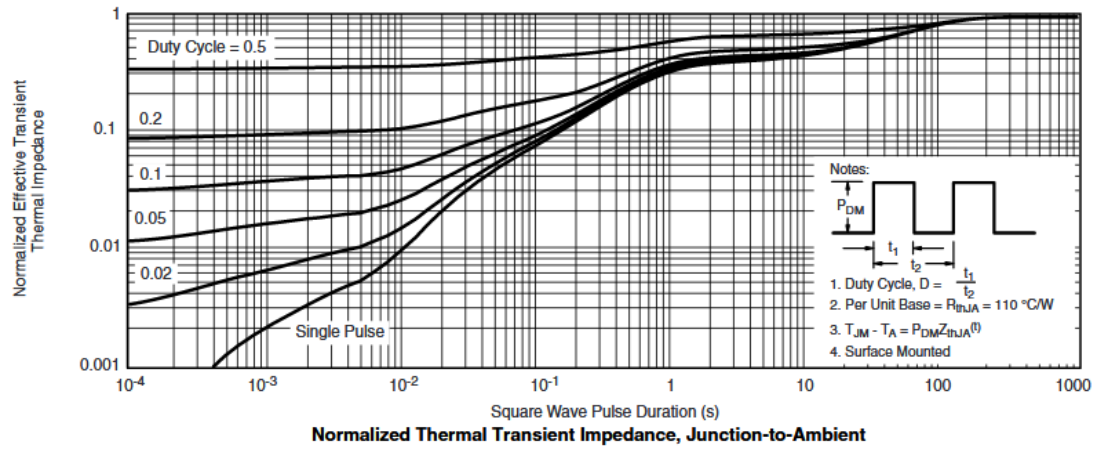



➤ Package Information

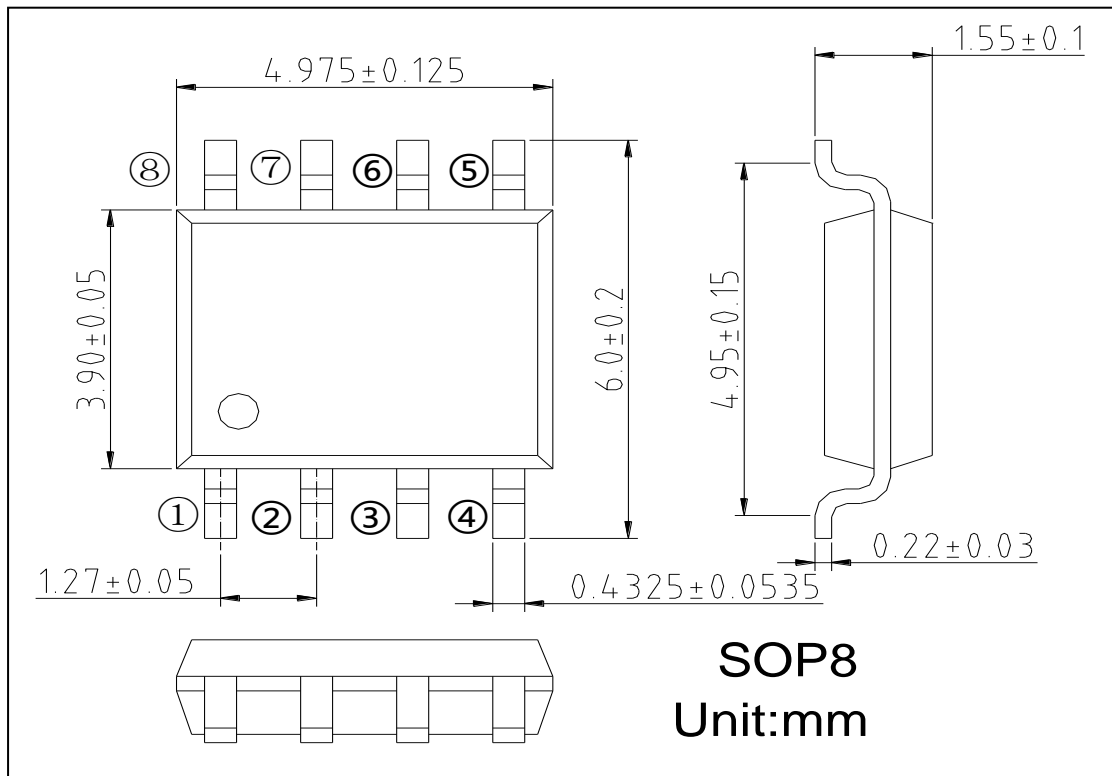

DISCLAIMER

SSCSEMI RESERVES THE RIGHT TO MAKE CHANGES WITHOUT FURTHER NOTICE TO ANY PRODUCTS HEREIN TO IMPROVE RELIABILITY, FUNCTION OR DESIGN. SSCSEMI DOES NOT ASSUME ANY LIABILITY ARISING OUT OF THE APPLICATION OR USE OF ANY PRODUCT OR CIRCUIT DESCRIBED HEREIN; NEITHER DOES IT CONVEY ANY LICENCE UNDER ITS PATENT RIGHTS, NOR THE RIGHTS OF OTHERS.

THE GRAPHS PROVIDED IN THIS DOCUMENT ARE STATISTICAL SUMMARIES BASED ON A LIMITED NUMBER OF SAMPLES AND ARE PROVIDED FOR INFORMATIONAL PURPOSE ONLY. THE PERFORMANCE CHARACTERISTICS LISTED IN THEM ARE NOT TESTED OR GUARANTEED. IN SOME GRAPHS, THE DATA PRESENTED MAY BE OUTSIDE THE SPECIFIED OPERATING RANGE (E.G. OUTSIDE SPECIFIED POWER SUPPLY RANGE) AND THEREFORE OUTSIDE THE WARRANTED RANGE.

OUR PRODUCT SPECIFICATIONS ARE ONLY VALID IF OBTAINED THROUGH THE COMPANY'S OFFICIAL WEBSITE, CRM SYSTEM, OR OUR SALES PERSONNEL CHANNELS. IF CHANGES OR SPECIAL VERSIONS ARE INVOLVED, THEY MUST BE STAMPED WITH A QUALITY SEAL AND MARKED WITH A SPECIAL VERSION NUMBER TO BE VALID.