



# SSC8129GS1

## P-Channel Enhancement Mode MOSFET

### ➤ Features

| VDS  | VGS  | RDS(on) Typ. | ID   |
|------|------|--------------|------|
| -20V | ±12V | 11mR@-4V5    | -15A |
|      |      | 13mR@-2V5    |      |

### ➤ Description

This device is produced with high cell density, DMOS trench technology, which is especially used to minimize on-state resistance. This device is particularly suited for low voltage power management requiring a wide range of given voltage ratings(4.5V-25V) such as load switch and battery protection.

### ➤ Applications

- Load Switch
- NB battery
- DCDC conversion

### ➤ Ordering Information

| Device     | Package | Shipping  |
|------------|---------|-----------|
| SSC8129GS1 | SOP8    | 2500/Reel |

### ➤ Pin configuration

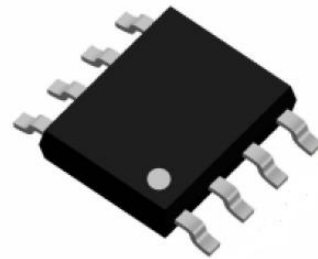
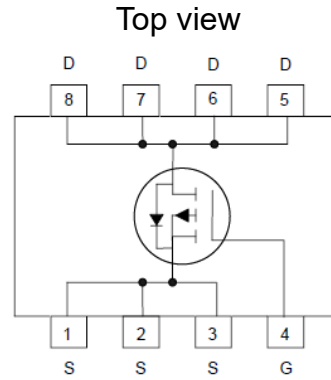

SOP8

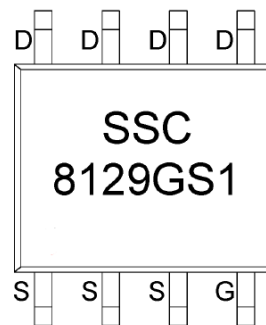

Marking



➤ **Absolute Maximum Ratings**( $T_A=25^{\circ}\text{C}$  unless otherwise noted)

| Symbol    | Parameter                             | Ratings    | Unit               |
|-----------|---------------------------------------|------------|--------------------|
| $V_{DSS}$ | Drain-to-Source Voltage               | -20        | V                  |
| $V_{GSS}$ | Gate-to-Source Voltage                | $\pm 12$   | V                  |
| $I_D$     | Continuous Drain Current <sup>a</sup> | -15        | A                  |
| $I_{DM}$  | Pulsed Drain Current <sup>b</sup>     | -41        | A                  |
| $P_D$     | Power Dissipation <sup>c</sup>        | 5.5        | W                  |
| $P_{DSM}$ | Power Dissipation <sup>a</sup>        | 2.5        | W                  |
| $T_J$     | Operation junction temperature        | -55 to 150 | $^{\circ}\text{C}$ |
| $T_{STG}$ | Storage temperature range             | -55 to 150 | $^{\circ}\text{C}$ |

➤ **Thermal Resistance Ratings**( $T_A=25^{\circ}\text{C}$  unless otherwise noted)

| Symbol          | Parameter   | Typical | Maximum | Unit                        |
|-----------------|---|---------|---------|-----------------------------|
| $R_{\theta JA}$ | Junction-to-Ambient Thermal Resistance <sup>a</sup> |         | 55      | $^{\circ}\text{C}/\text{W}$ |
| $R_{\theta JC}$ | Junction-to-Case Thermal Resistance                 |         | 25      |                             |

Note:

- The value of  $R_{\theta JA}$  is measured with the device mounted on 1 in<sup>2</sup> FR-4 board with 2oz.copper,in a still air environment with  $T_A=25^{\circ}\text{C}$ .The value in any given application depends on the user is specific board design. The current rating is based on the  $t \leq 10\text{s}$  thermal resistance rating.
- Repetitive rating, pulse width limited by junction temperature.
- The power dissipation  $P_D$  is based on  $T_{J(MAX)}=150^{\circ}\text{C}$ , using junction-to-case thermal resistance, and is more useful in setting the upper dissipation limit for cases where additional heat sinking is used.



➤ **Electronics Characteristics**( $T_A=25^{\circ}\text{C}$  unless otherwise noted)

| Symbol        | Parameter                          | Test Conditions  | Min  | Typ. | Max       | Unit    |
|---------------|------------------------------------|--|------|------|-----------|---------|
| $V_{(BR)DSS}$ | Drain-Source<br>Breakdown Voltage  | $V_{GS}=0V, I_D=-250\mu A$                             | -20  |      |           | V       |
| $V_{GS(th)}$  | Gate Threshold<br>Voltage          | $V_{DS}=V_{GS}, I_D=-250\mu A$                         | -0.5 | -0.7 | -1        | V       |
| $R_{DS(on)}$  | Drain-Source On-<br>Resistance     | $V_{GS}=-4.5V, I_D=-10A$                               |      | 11   | 13        | mR      |
|               |                                    | $V_{GS}=-2.5V, I_D=-7A$                                |      | 13   | 16        |         |
| $I_{DSS}$     | Zero Gate Voltage<br>Drain Current | $V_{DS}=-16V, V_{GS}=0V$                               |      |      | -1        | $\mu A$ |
| $I_{GSS}$     | Gate-Source leak<br>current        | $V_{GS}=\pm 12V, V_{DS}=0V$                            |      |      | $\pm 100$ | nA      |
| $G_{FS}$      | Trans conductance                  | $V_{DS}=-5V, I_D=-10A$                                 |      | 18   |           | S       |
| $V_{SD}$      | Forward Voltage                    | $V_{GS}=0V, I_S=-2.3A$                                 |      | -0.7 | -1.3      | V       |
| $C_{iss}$     | Input Capacitance                  | $V_{DS}=-15V, V_{GS}=0V,$<br>$f=1MHz$                  |      | 1820 |           | pF      |
| $C_{oss}$     | Output Capacitance                 |  |      | 489  |           |         |
| $C_{rss}$     | Reverse Transfer<br>Capacitance    |  |      | 663  |           |         |
| $Q_g$         | Total Gate charge                  | $V_{GS}=-4.5V, V_{DS}=-15V,$<br>$I_D=-7A$              |      | 22   |           | nC      |
| $Q_{gs}$      | Gate to Source<br>charge           |  |      | 2.5  |           |         |
| $Q_{gd}$      | Gate to Drain<br>charge            |  |      | 6    |           |         |
| $T_{D(ON)}$   | Turn-on delay time                 | $V_{GS}=-10V,$<br>$V_{DS}=-15V, R_L=1.5R,$<br>$R_G=3R$ |      | 11   |           | ns      |
| $T_r$         | Rise time                          |  |      | 22   |           |         |
| $T_{D(OFF)}$  | Turn-off delay time                |  |      | 51   |           |         |
| $T_f$         | Fall time                          |  |      | 24   |           |         |



➤ **Typical Characteristics** ( $T_A=25^\circ\text{C}$  unless otherwise noted)

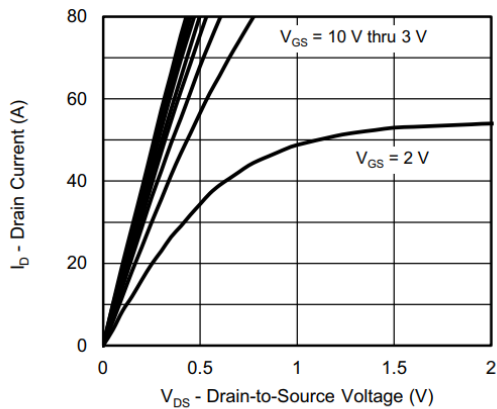

**Output Characteristics**

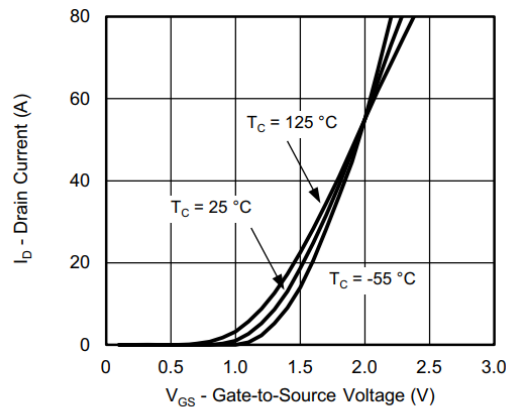

**Transfer Characteristics**

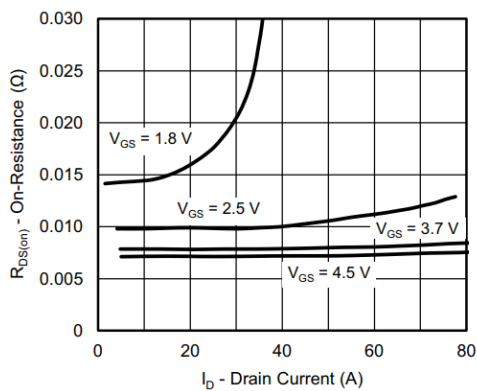

**On-Resistance vs. Drain Current and Gate Voltage**

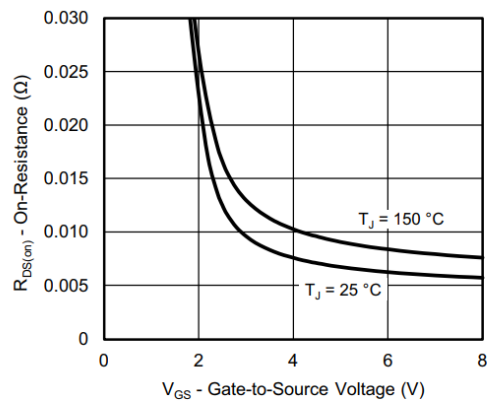

**On-Resistance vs. Gate-to-Source Voltage**

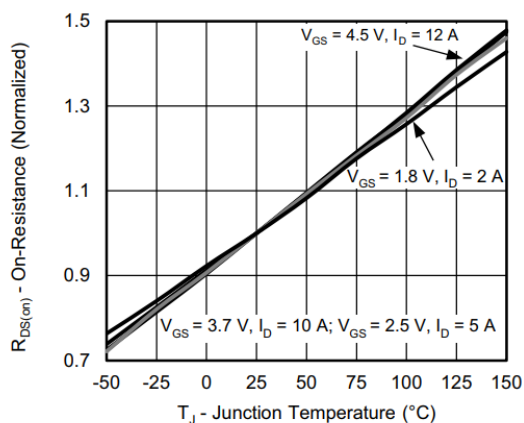

**On-Resistance vs. Junction Temperature**

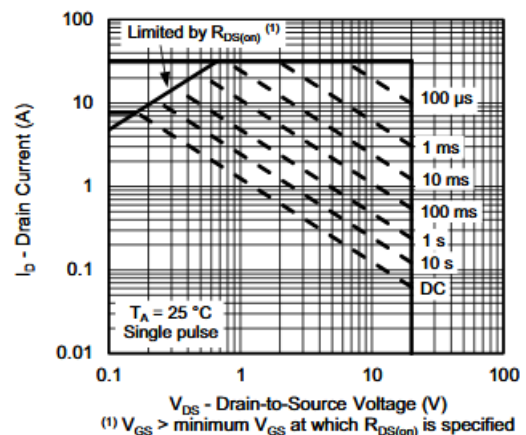

**Safe Operating Area, Junction-to-Ambient**

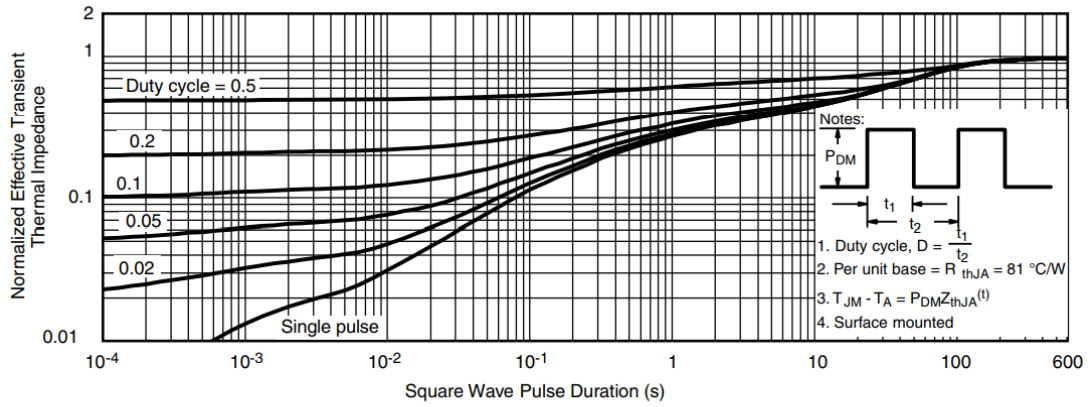

Normalized Thermal Transient Impedance, Junction-to-Ambient



➤ Package Information

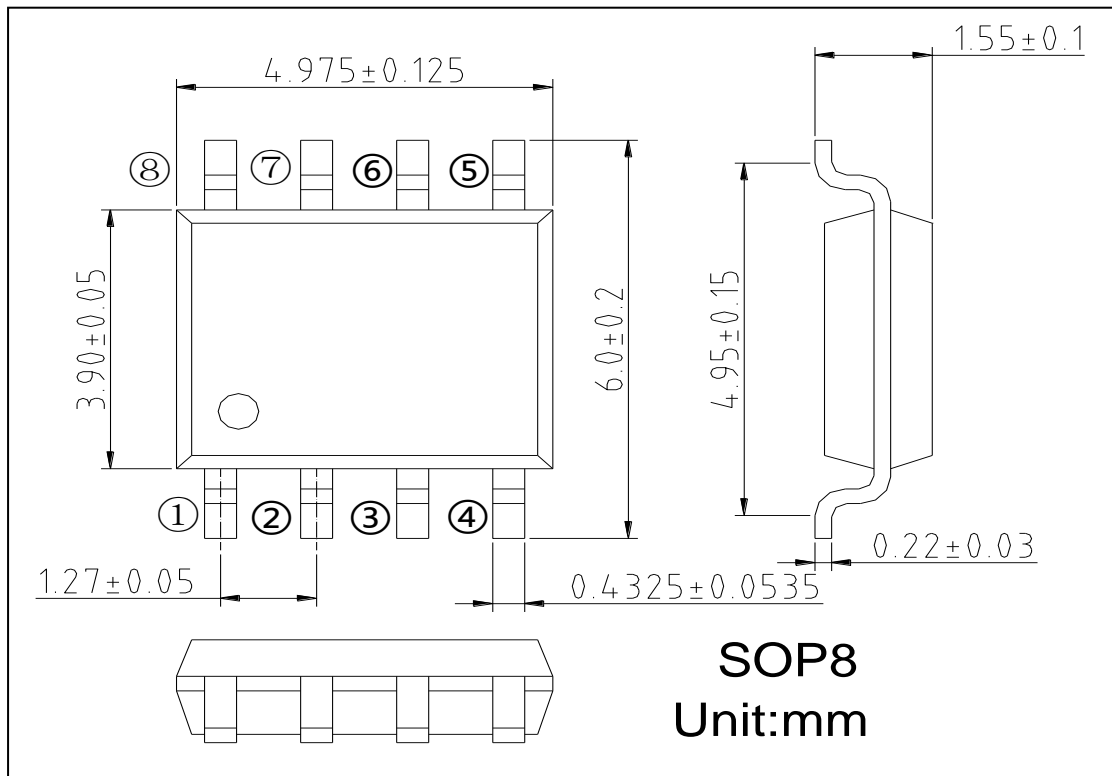

**DISCLAIMER**

SSCSEMI RESERVES THE RIGHT TO MAKE CHANGES WITHOUT FURTHER NOTICE TO ANY PRODUCTS HEREIN TO IMPROVE RELIABILITY, FUNCTION OR DESIGN. SSCSEMI DOES NOT ASSUME ANY LIABILITY ARISING OUT OF THE APPLICATION OR USE OF ANY PRODUCT OR CIRCUIT DESCRIBED HEREIN; NEITHER DOES IT CONVEY ANY LICENCE UNDER ITS PATENT RIGHTS, NOR THE RIGHTS OF OTHERS.

THE GRAPHS PROVIDED IN THIS DOCUMENT ARE STATISTICAL SUMMARIES BASED ON A LIMITED NUMBER OF SAMPLES AND ARE PROVIDED FOR INFORMATIONAL PURPOSE ONLY. THE PERFORMANCE CHARACTERISTICS LISTED IN THEM ARE NOT TESTED OR GUARANTEED. IN SOME GRAPHS, THE DATA PRESENTED MAY BE OUTSIDE THE SPECIFIED OPERATING RANGE (E.G. OUTSIDE SPECIFIED POWER SUPPLY RANGE) AND THEREFORE OUTSIDE THE WARRANTED RANGE.

OUR PRODUCT SPECIFICATIONS ARE ONLY VALID IF OBTAINED THROUGH THE COMPANY'S OFFICIAL WEBSITE, CRM SYSTEM, OR OUR SALES PERSONNEL CHANNELS. IF CHANGES OR SPECIAL VERSIONS ARE INVOLVED, THEY MUST BE STAMPED WITH A QUALITY SEAL AND MARKED WITH A SPECIAL VERSION NUMBER TO BE VALID.