



SSC8037GS1

P-Channel Enhancement Mode MOSFET

➤ Features

VDS	VGS	RDSON Typ.	ID
-30V	±25V	15mR@-10V	-34A
		23mR@-4V5	

➤ Description

This device is produced with high cell density DMOS trench technology, uses advanced trench technology and design to provide excellent RDSON with low gate charge. This device particularly suits low voltage applications such as portable equipment, power management and other battery powered circuits, and low in-line power dissipation are needed in a very small outline surface mount package.

100% UIS Tested.

➤ Applications

- Load Switch
- NB battery
- DCDC conversion

➤ Ordering Information

Device	Package	Shipping
SSC8037GS1	SOP8	2500/Reel

➤ Pin configuration

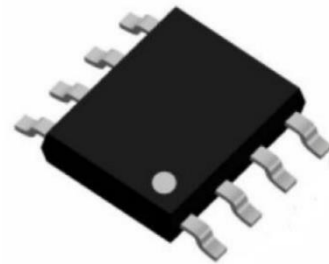
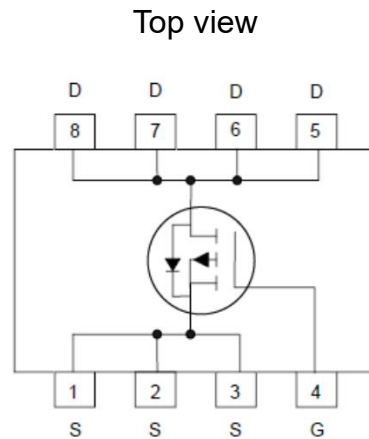

Bottom View



(Y: year/W: week)

Marking

**➤ Absolute Maximum Ratings**($T_A=25^{\circ}\text{C}$ unless otherwise noted)

Symbol	Parameter	Ratings	Unit	
V_{DSS}	Drain-to-Source Voltage	-30	V	
V_{GSS}	Gate-to-Source Voltage	± 25	V	
I_D	Continuous Drain Current ^d	TC=25 $^{\circ}\text{C}$	-34	A
		TC=100 $^{\circ}\text{C}$	-19	
I_{DSM}	Continuous Drain Current ^a	TA=25 $^{\circ}\text{C}$	-10.7	A
		TA=70 $^{\circ}\text{C}$	-7.8	
I_{DM}	Pulsed Drain Current ^b	-136	A	
I_{AS}	Avalanche Current ^b L=0.5mH	-21	A	
E_{AS}	Avalanche Energy ^b L=0.5mH	110	mJ	
P_D	Power Dissipation ^d	TC=25 $^{\circ}\text{C}$	28	W
		TC=100 $^{\circ}\text{C}$	11	W
P_{DSM}	Power Dissipation ^a	TA=25 $^{\circ}\text{C}$	2.8	W
		TA=70 $^{\circ}\text{C}$	1.8	W
T_J	Operation junction temperature	-55 to 150	$^{\circ}\text{C}$	
T_{STG}	Storage temperature range	-55 to 150		

➤ Thermal Resistance Ratings($T_A=25^{\circ}\text{C}$ unless otherwise noted)

Symbol	Parameter	Ratings	Unit
$R_{\theta JA}$	Junction-to-Ambient Thermal Resistance ^a	45	$^{\circ}\text{C}/\text{W}$
$R_{\theta JC}$	Junction-to-Case Thermal Resistance ^c	22	
	Junction-to-Case Thermal Resistance ^d	4.4	

Note:

- The value of $R_{\theta JA}$ is measured with the device mounted on 1 in² FR-4 board with 2oz.copper,in a still air environment with $T_A=25^{\circ}\text{C}$.The value in any given application depends on the user is specific board design. The current rating is based on the $t \leq 10\text{s}$ thermal resistance rating.
- Repetitive rating, pulse width limited by junction temperature.
- The power dissipation P_D is based on $T_J(\text{MAX})=150^{\circ}\text{C}$, using junction-to-case thermal resistance, and is more useful in setting the upper dissipation limit for cases where additional heat sinking is used.
- The value of $R_{\theta JC}$ has been determined of the temperature difference between junction and the case surface in contact with water cooled copper heat sink .



➤ **Electronics Characteristics**($T_A=25^{\circ}\text{C}$ unless otherwise noted)

Symbol	Parameter	Test Conditions	Min	Typ.	Max	Unit
$V_{(BR)DSS}$	Drain-Source Breakdown Voltage	$V_{GS}=0V, I_D=-250\mu A$	-30			V
$V_{GS(th)}$	Gate Threshold Voltage	$V_{DS}=V_{GS}, I_D=-250\mu A$	-1	-1.6	-3	V
$R_{DS(on)}$	Drain-Source On-Resistance	$V_{GS}=-10V, I_D=-10A$		15	19	mR
		$V_{GS}=-4.5V, I_D=-7A$		23	30	
I_{DSS}	Zero Gate Voltage Drain Current	$V_{DS}=-30V, V_{GS}=0V$			-1	μA
I_{GSS}	Gate-Source leak current	$V_{GS}=\pm 25V, V_{DS}=0V$			± 100	nA
G_{FS}	Transconductance	$V_{DS}=-5V, I_D=-5A$		11		S
V_{SD}	Forward Voltage	$V_{GS}=0V, I_S=-5A$		-0.8	-1.3	V
C_{iss}	Input Capacitance	$V_{DS}=-15V, V_{GS}=0V, f=1MHz$		1300		pF
C_{oss}	Output Capacitance			161		
C_{rss}	Reverse Transfer Capacitance			183		
Q_G	Total Gate charge	$V_{GS}=-10V, V_{DS}=-15V, I_D=-10A$		25.5		nC
Q_{GS}	Gate to Source charge			4.3		
Q_{GD}	Gate to Drain charge			6.1		
$T_{D(ON)}$	Turn-on delay time	$V_{GS}=-10V, V_{DS}=-15V, R_L=1R, R_G=3R$		8		ns
T_r	Rise time			33.5		
$T_{D(OFF)}$	Turn-off delay time			48		
T_f	Fall time			11		
T_{rr}	Diode Recovery Time	$I_F=-10A, di/dt=200A/\mu s$		23		ns
Q_{rr}	Diode Recovery Charge			8		nC



➤ Typical Characteristics ($T_A=25^\circ\text{C}$ unless otherwise noted)

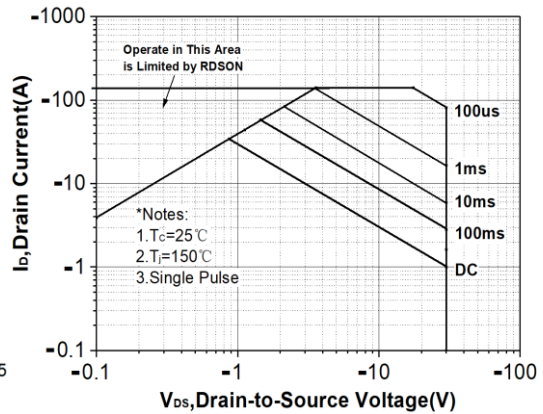
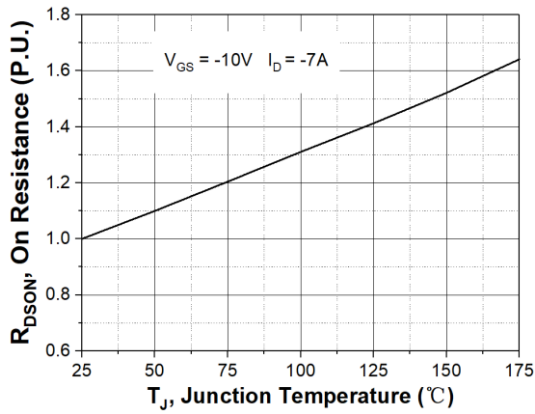
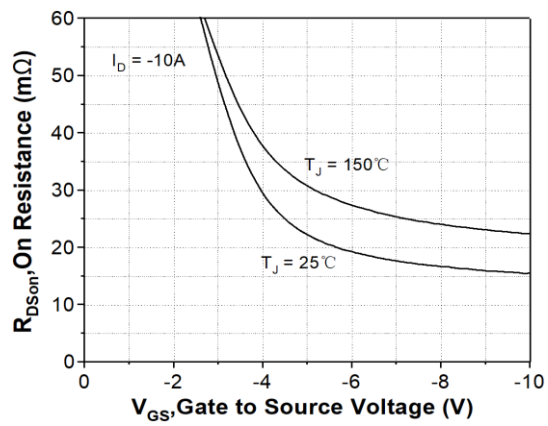
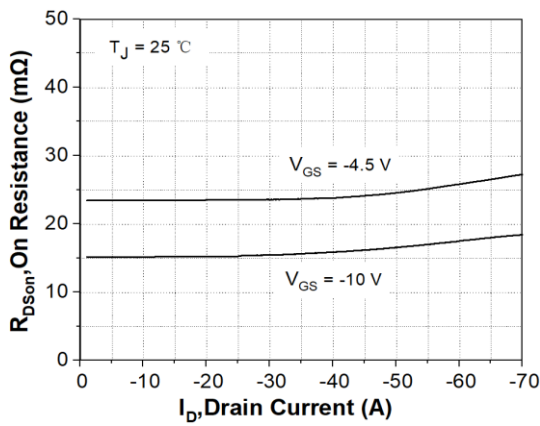
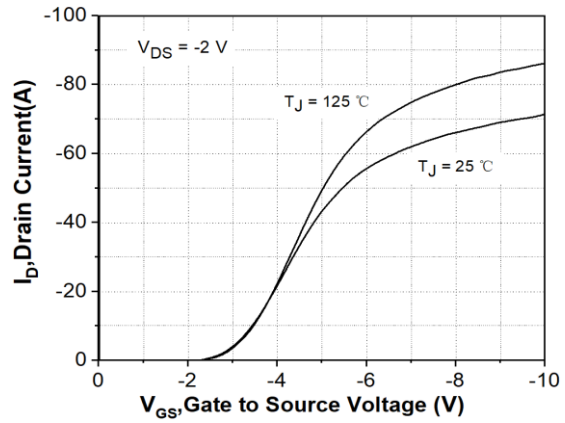
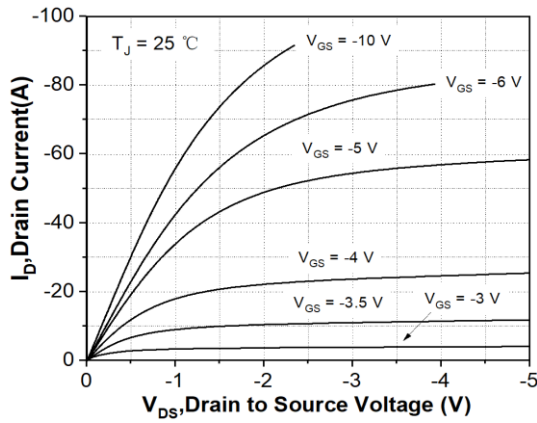

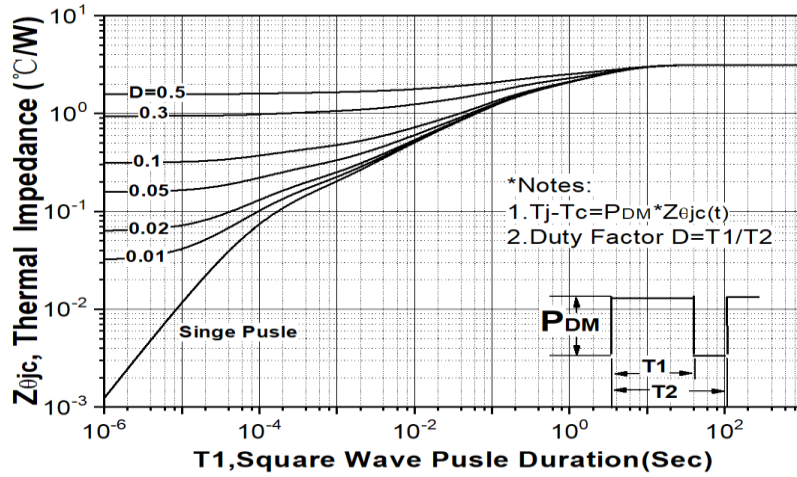

➤ Package Information

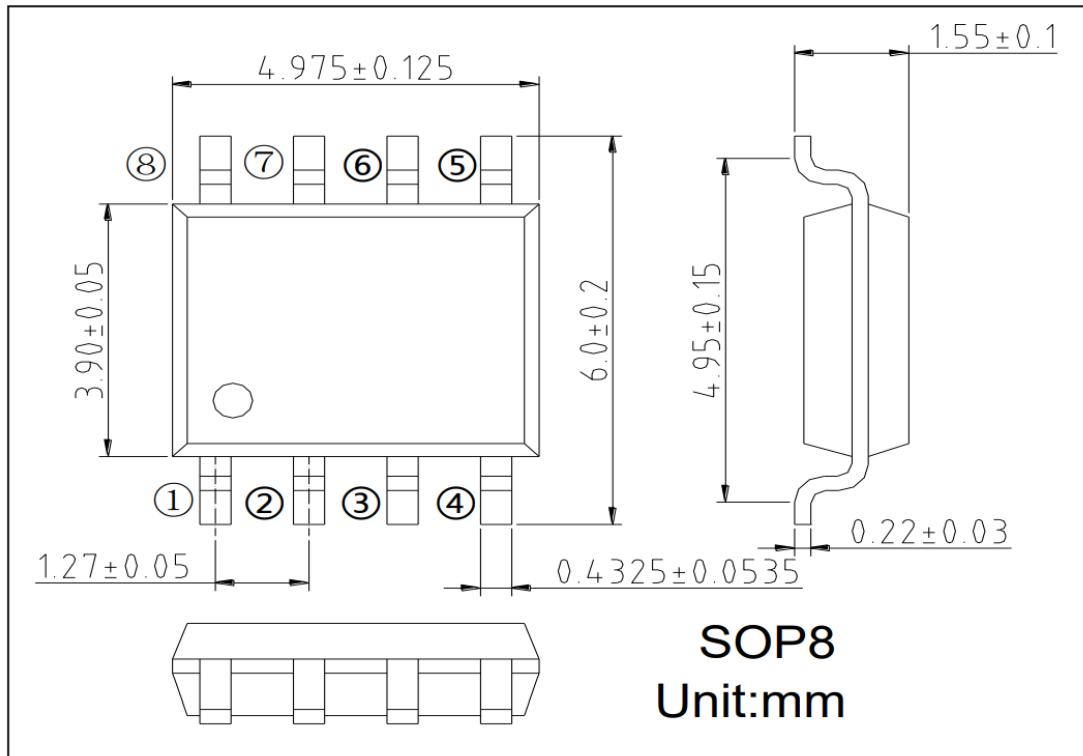



DISCLAIMER

SSCSEMI RESERVES THE RIGHT TO MAKE CHANGES WITHOUT FURTHER NOTICE TO ANY PRODUCTS HEREIN TO IMPROVE RELIABILITY, FUNCTION OR DESIGN. SSCSEMI DOES NOT ASSUME ANY LIABILITY ARISING OUT OF THE APPLICATION OR USE OF ANY PRODUCT OR CIRCUIT DESCRIBED HEREIN; NEITHER DOES IT CONVEY ANY LICENCE UNDER ITS PATENT RIGHTS, NOR THE RIGHTS OF OTHERS.

THE GRAPHS PROVIDED IN THIS DOCUMENT ARE STATISTICAL SUMMARIES BASED ON A LIMITED NUMBER OF SAMPLES AND ARE PROVIDED FOR INFORMATIONAL PURPOSE ONLY. THE PERFORMANCE CHARACTERISTICS LISTED IN THEM ARE NOT TESTED OR GUARANTEED. IN SOME GRAPHS, THE DATA PRESENTED MAY BE OUTSIDE THE SPECIFIED OPERATING RANGE (E.G. OUTSIDE SPECIFIED POWER SUPPLY RANGE) AND THEREFORE OUTSIDE THE WARRANTED RANGE.

OUR PRODUCT SPECIFICATIONS ARE ONLY VALID IF OBTAINED THROUGH THE COMPANY'S OFFICIAL WEBSITE, CRM SYSTEM, OR OUR SALES PERSONNEL CHANNELS. IF CHANGES OR SPECIAL VERSIONS ARE INVOLVED, THEY MUST BE STAMPED WITH A QUALITY SEAL AND MARKED WITH A SPECIAL VERSION NUMBER TO BE VALID.