



SSC1N4148D3

Fast Switching Diode

● Features

- ✧ Fast Switching Speed
- ✧ Ultra-Small Surface Mount Package
- ✧ Low Reverse Leakage Current
- ✧ Ideal for Battery Powered Portable Applications
- ✧ RoHS Compliant/Green EMC
- ✧ Moisture Sensitivity: Level 3 per J-STD-020

● PIN configuration

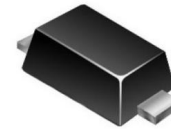

SOD-523



Circuit Diagram

● Applications

- ✧ High speed switching for detection
- ✧ Battery Powered Portable
- ✧ Mobile phones, laptops and other electronic devices



Marking(Top View)

● Absolute maximum rating @T_A=25°C

Parameter	Symbol	Value	Unit
Non-Repetitive Peak Reverse Voltage	V _{RM}	100	V
Repetitive Peak Reverse Voltage	V _{RRM}	75	V
Working Peak Reverse Voltage	V _{RWM}		
Reverse Voltage(DC)	V _R		
RMS Reverse Voltage	V _{RMS}	53	V
Forward Continuous Current	I _{FM}	300	mA
Average Rectified Forward Current	I _o	150	mA
Non-Repetitive Peak Forward Surge Current@ t=8.3ms	I _{FSM}	2	A
Power Dissipation	P _D	150	mW
Thermal Resistance from Junction to Ambient	R _{θJA}	833	°C/W
Operating Temperature	T _J	-55 ~ +150	°C
Storage Temperature	T _{STG}	-55 ~ +150	°C



Electrical Characteristics @T_A=25°C

Parameter	Symbol	Conditions	Min.	Typ.	Max.	Unit
Reverse Voltage	V _{R1}	I _R = 100μA	100			V
Forward Voltage	V _F	I _F = 1mA			0.715	V
		I _F = 10mA			0.855	
		I _F = 50mA			1	
		I _F = 150mA			1.25	
Reverse Current	I _R	V _R = 20V			25	nA
		V _R = 75V			1	μA
Total Capacitance	C _T	V _R = 0, f = 1MHz			2	pF
Reverse Recovery Time	t _{rr}	I _F = I _R = 10mA, I _{rr} = 0.1 x I _R , R _L = 100Ω			4	ns

Typical Performance Characteristics

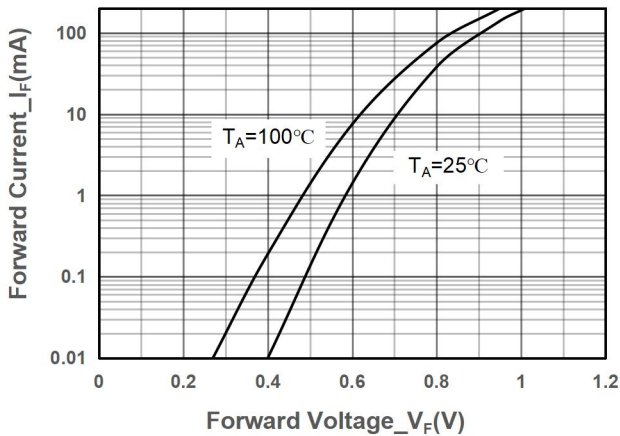

Forward Voltage vs. Forward Current

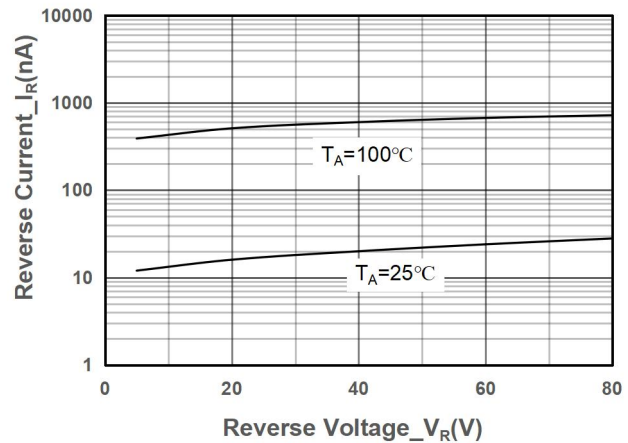

Reverse Voltage vs. Reverse Current

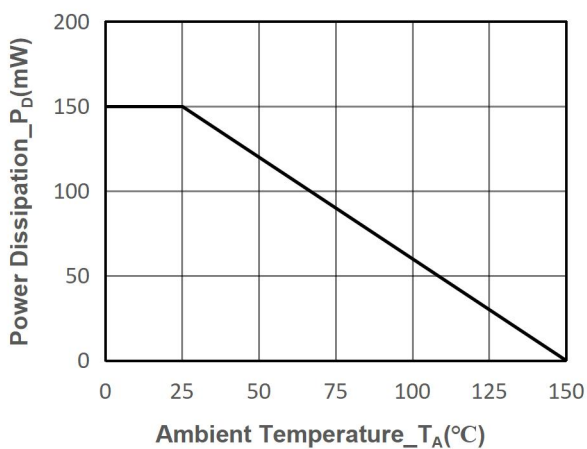

Power Derating vs. Ambient Temperature

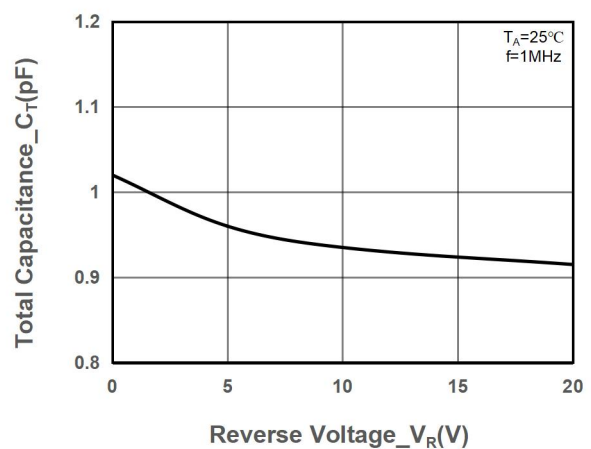

Total Capacitance vs. Reverse Voltage



SSC1N4148D3

● Package Information

Ordering Information

Device	Package	Marking	Qty per Reel	Reel Size
SSC1N4148D3	SOD-523	T4	3000	7 Inch

Mechanical Data

Case: SOD-523

Case Material: Molded Plastic. UL Flammability

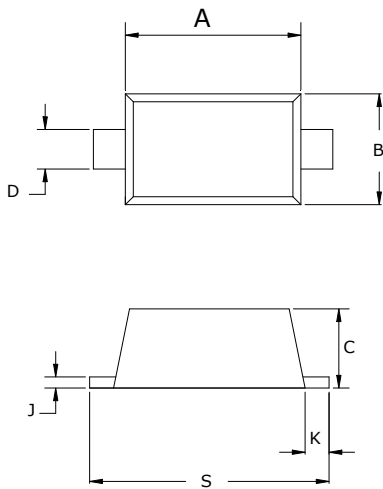

DIM	Millimeters	
	Min	Max
A	1.10	1.30
B	0.75	0.85
C	0.51	0.70
D	0.25	0.35
J	0.08	0.15
K	0.15	0.25
S	1.50	1.70

Recommended Pad outline (Unit:mm)

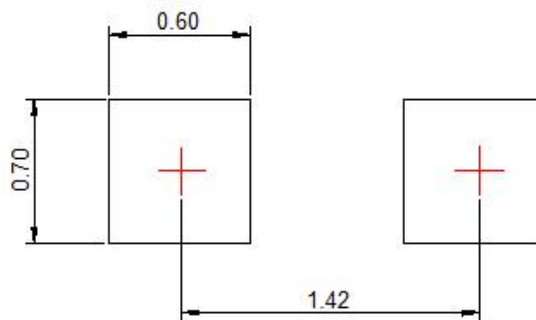



DISCLAIMER

SSCSEMI RESERVES THE RIGHT TO MAKE CHANGES WITHOUT FURTHER NOTICE TO ANY PRODUCTS HEREIN TO IMPROVE RELIABILITY, FUNCTION OR DESIGN. SSCSEMI DOES NOT ASSUME ANY LIABILITY ARISING OUT OF THE APPLICATION OR USE OF ANY PRODUCT OR CIRCUIT DESCRIBED HEREIN; NEITHER DOES IT CONVEY ANY LICIENCE UNDER ITS PATENT RIGHTS, NOR THE RIGHTS OF OTHERS.

THE GRAPHS PROVIDED IN THIS DOCUMENT ARE STATISTICAL SUMMARIES BASED ON A LIMITED NUMBER OF SAMPLES AND ARE PROVIDED FOR INFORMATIONAL PURPOSE ONLY. THE PERFORMANCE CHARACTERISTICS LISTED IN THEM ARE NOT TESTED OR GUARANTEED. IN SOME GRAPHS, THE DATA PRESENTED MAY BE OUTSIDE THE SPECIFIED OPERATING RANGE (E.G., OUTSIDE SPECIFIED POWER SUPPLY RANGE) AND THEREFORE OUTSIDE THE WARRANTED RANGE.

OUR PRODUCT SPECIFICATIONS ARE ONLY VALID IF OBTAINED THROUGH THE COMPANY'S OFFICIAL WEBSITE, CRM SYSTEM, OR OUR SALES PERSONNEL CHANNELS. IF CHANGES OR SPECIAL VERSIONS ARE INVOLVED, THEY MUST BE STAMPED WITH A QUALITY SEAL AND MARKED WITH A SPECIAL VERSION NUMBER TO BE VALID.