



6V Input , 500mA , Good Transient Response Low Voltage , CMOS LDO

Description

The AF6219 series are CMOS-based LDO regulators featuring 500mA output current. Internally, the IC consists of a voltage reference unit, an error amplifier and a current limit circuit. AF6219 also features an excellent line transient response, super high ripple rejection and low noise.

The series are very suitable for the battery-powered equipment such as RF applications and other systems requiring a quiet voltage source. Extends battery life in portable electronics

Applications

- Portable consumer equipment
- Wireless handsets, Smart Phones
- Bluetooth, Digital cameras and Digital audio
- PDAs and other handheld products

Device Information

AF 6219/6219N – XX C/D/M

- ① ② ③ ④

①	Standard
②	Product Name AF6219: with OTP AF6219N: without OTP
③	Output Voltage e.g. 25 = 2.5V
④	C: SOT23-5L Package
	D: DFN1X1-4L Package
	M: SOT23-3L Package

Features

- Input Voltage Range: 2V~6V
- Output Voltage Range: 1V~5V
- Output Current: 500mA
- Quiescent Current: 50uA
- Dropout Voltage: 150mV@150mA
- Voltage Accuracy: ±2%(Typ.)
- PSRR: 75dB at 1kHz
- Excellent Line and Load Transient Response
- Short-Circuit Protection
- Built-in Current Limiter
- Low Output Noise
- Over-Temperature Protection

Typical Application

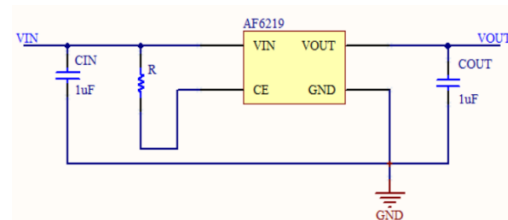

Pin Configuration

Symbol	Package Pin		
	SOT23-5L	DFN1X1-4L	SOT23-3L
VIN	1	4	3
GND	2	2	1
CE	3	3	
NC	4		
OUT	5	1	2

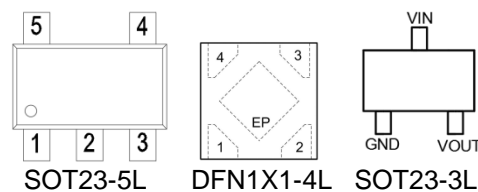



AF6219 Series

Absolute Maximum Ratings ⁽¹⁾

(Unless otherwise specified, all voltages are with respect to GND, TA=25°C)

PARAMETER		SYMBOL	RATINGS	UNITS
Input Voltage		V_{IN}	-0.3~7	V
Output Voltage		V_{OUT}	-0.3~5	V
Output Current		I_{OUT}	500	mA
Power Dissipation	SOT23-5	P_D	0.4	W
	DFN1X1-4L			
	SOT23-3			
Operating Junction Temperature Range		T_J	-40~125	°C
Storage Temperature		T_{STG}	-40~125	°C
Lead Temperature(Soldering, 10 sec)		T_L	260	°C
Package Thermal Resistance	SOT23-5	θ_{JA}	250	°C/W
	DFN1X1-4L			
	SOT23-3			

(1). Stresses beyond those listed under absolute maximum ratings may cause permanent damage to the device. These are stress ratings only, and functional operation of the device at these or any other conditions beyond those indicated under recommended operating conditions is not implied. Exposure to absolute-maximum-rated conditions for extended periods may affect device reliability.



✚ Electronics Characteristics

(Unless otherwise specified, $V_{IN}=V_{OUT}+1V$, $C_{IN}=C_{OUT}=1\mu F$, $T_A=25^\circ C$)

PARAMETER	SYMBOL	CONDITIONS	MIN	TYP	MAX	UNIT
Input Voltage	V_{IN}		2		6	V
Output Voltage	V_{OUT}		0.98 V_{OUT}	V_{OUT}	1.02 V_{OUT}	V
Dropout Voltage	V_{DIF}	$I_{OUT}=150mA$ $V_{OUT}=1.2V$		390	420	mV
		$I_{OUT}=150mA$ $V_{OUT}=1.5V$		280	300	mV
		$I_{OUT}=150mA$ $V_{OUT}=1.8V$		220	250	mV
		$I_{OUT}=150mA$ $V_{OUT}=2.5V$		175	220	mV
		$I_{OUT}=150mA$ $V_{OUT}\geq 2.8V$		150	220	mV
Quiescent Current	I_Q	$I_{OUT}=0$		50	100	μA
Shutdown current	I_{CEL}	$V_{CE}=V_{SS}$		0.1	1	μA
Line Regulation	ΔV_{LINE}	$I_{OUT}=10mA$ $V_{OUT}+1V\leq V_{IN}\leq 6V$		0.01	0.2	%/V
Load Regulation	ΔV_{LOAD}	$V_{IN}=V_{OUT}+1V$ $1mA\leq I_{OUT}\leq 100mA$		10		mV
Temperature Coefficient	TC	$I_{OUT}=10mA$ $-40^\circ C < T_A < 125^\circ C$		50		ppm
Short Current	I_{SHORT}	$V_{OUT}=V_{SS}$		100		mA
Power Supply Rejection Ratio	PSRR	$I_{OUT}=5$ $0mA$	1kHz	75		dB
			10kHz	70		
CE "High"	VCE"H"		1.5		V_{IN}	V
CE "Low"	VCE"L"				0.4	V
Output Noise		10Hz~100kHz		40		μV_{RMS}
Discharge Resistance	$R_{DISCHRG}$	$V_{IN}=4.3V$ $V_{CE}=0V$		40		Ω
Thermal Shutdown Temperature	T_{SD}			150		$^\circ C$
Thermal Shutdown Hysteresis	ΔT_{SD}			20		$^\circ C$



Typical Characteristics

(Unless otherwise specified, $V_{IN}=V_{OUT}+1V$, $C_{IN}=C_{OUT}=1\mu F$, $T_A=25^\circ C$)

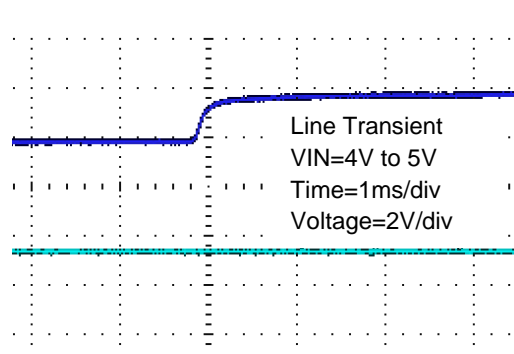
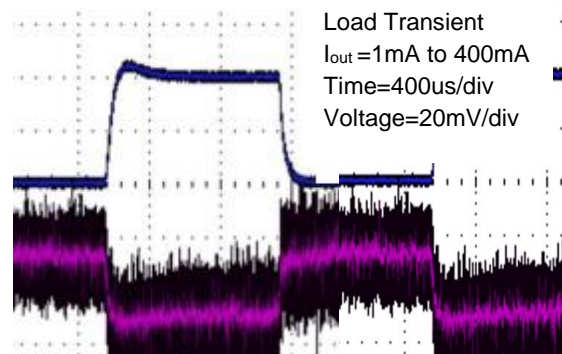
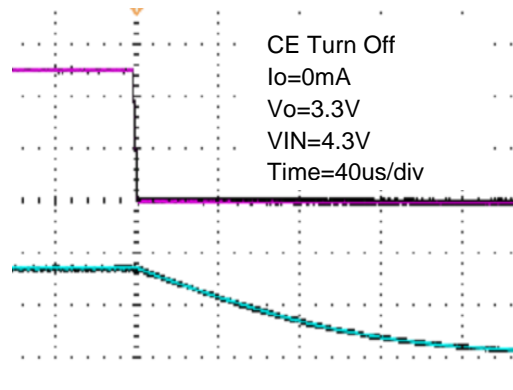
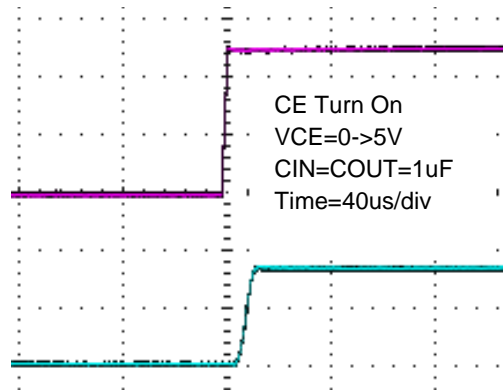
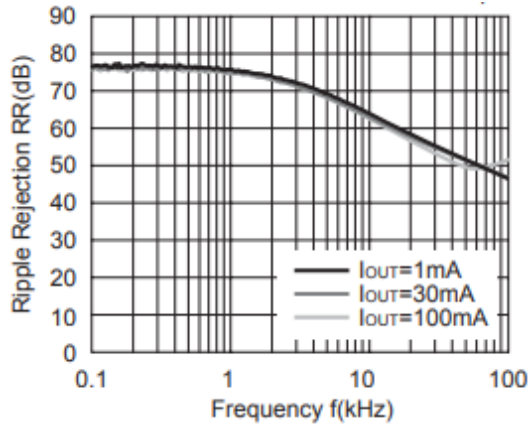
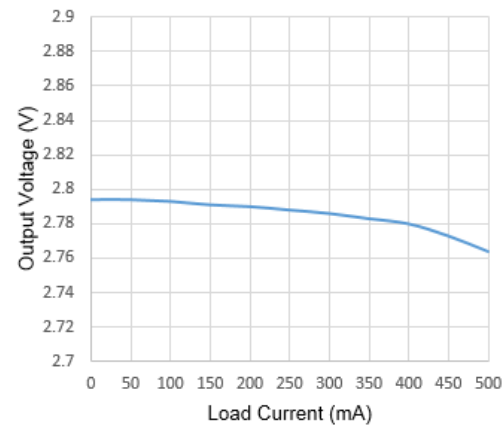
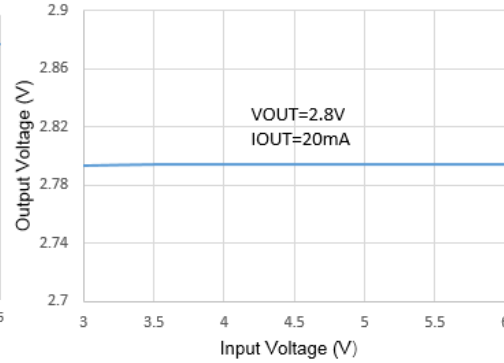
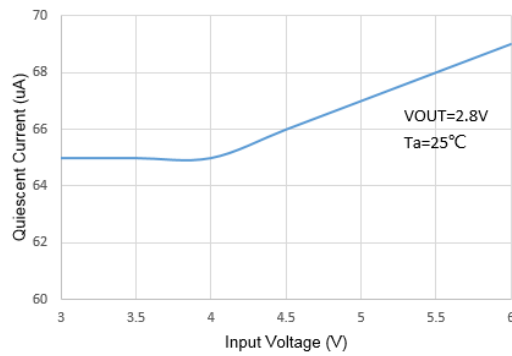



Package Information

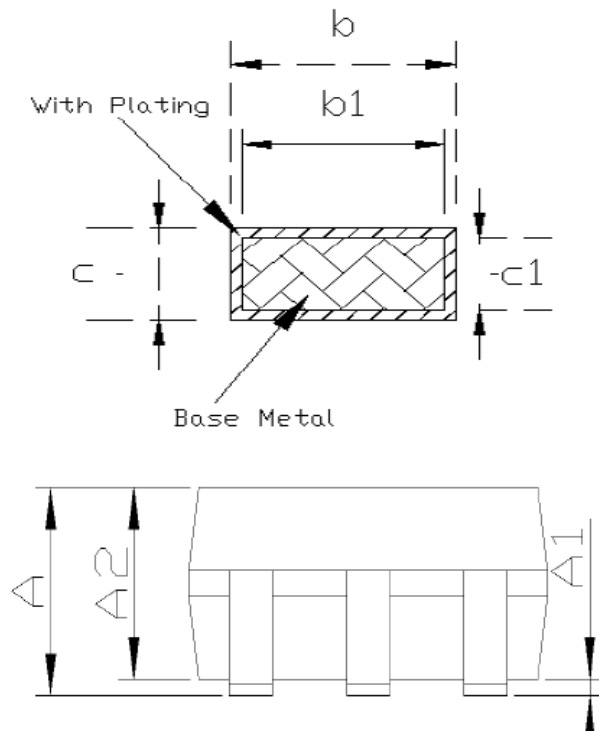

Common Dimensions (Units of Measure=Millimeter)			
SYMBOL	MINIMUM	NOMINAL	MAXIMUM
A	-	-	1.35
A1	0	-	0.15
A2	1.00	1.10	1.20
b	0.35	-	0.45
b1	0.32	-	0.38
c	0.14	-	0.20
c1	0.14	0.15	0.16
D	2.82	2.92	3.02
E	2.60	2.80	3.00
E1	1.526	1.626	1.726
e	0.90	0.95	1.00
e1	1.80	1.90	2.00
L	0.35	0.45	0.60
L1	0.6 REF		
L2	0.25 REF		
R	0.10	-	-
R1	0.10	-	0.25
θ	0°	4°	8°
θ 1	5°	10°	15°

SOT23-5L

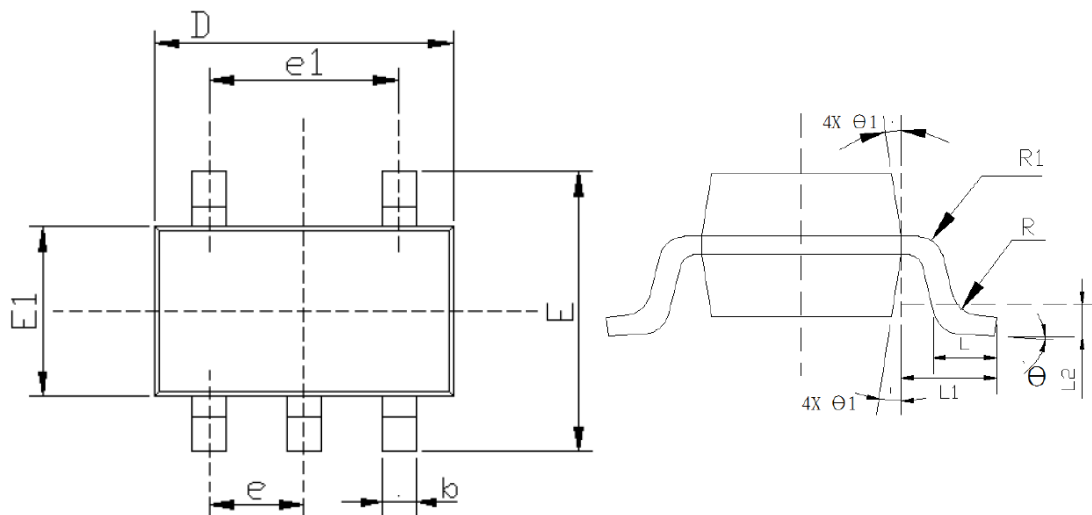

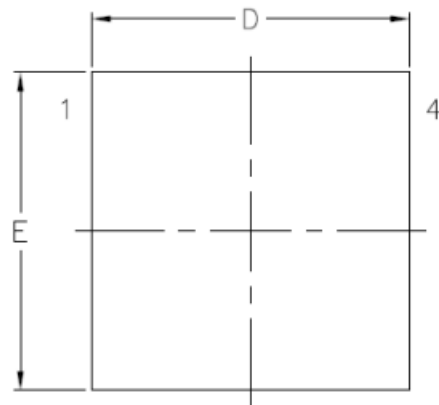
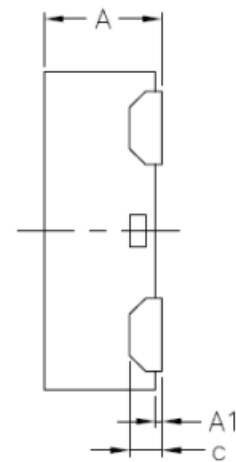
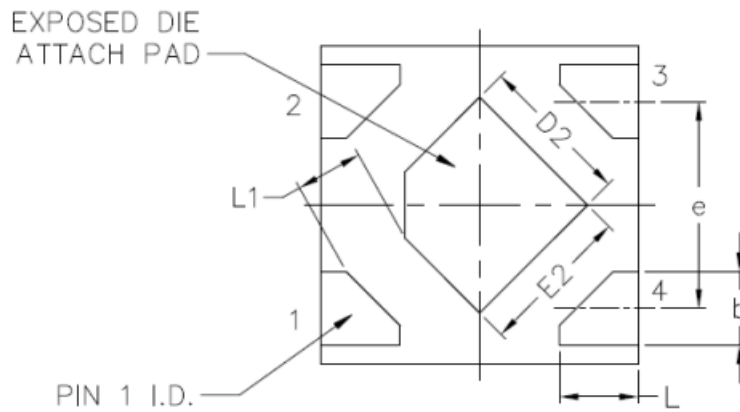
DFN1X1-4L

TOP VIEW

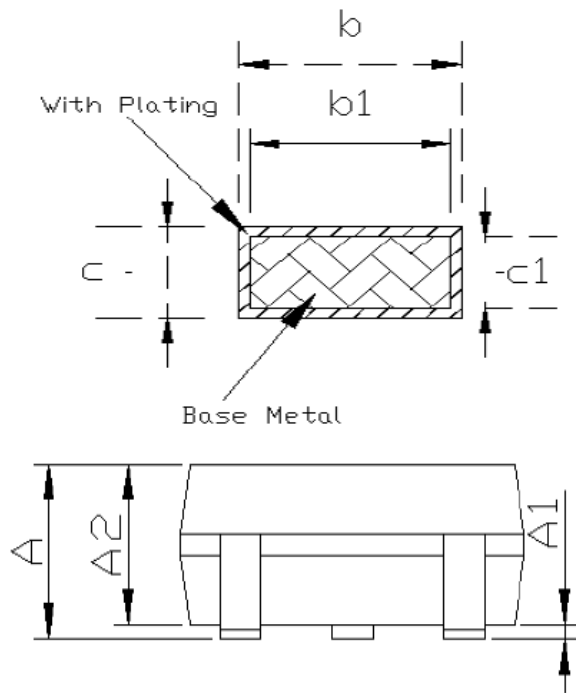
SIDE VIEW

BOTTOM VIEW

尺寸 标注	最小 (mm)	标准 (mm)	最大 (mm)	尺寸 标注	最小 (mm)	标准 (mm)	最大 (mm)
A	0.32	0.37	0.41	e	0.65 BSC		
A1	0.00	0.02	0.05	E	0.95	1.00	1.05
b	0.18	0.23	0.28	E2	0.43	0.48	0.53
c	0.102 REF			L	0.20	0.25	0.30
D	0.95	1.00	1.05	L1	0.205 REF		
D2	0.43	0.48	0.53				

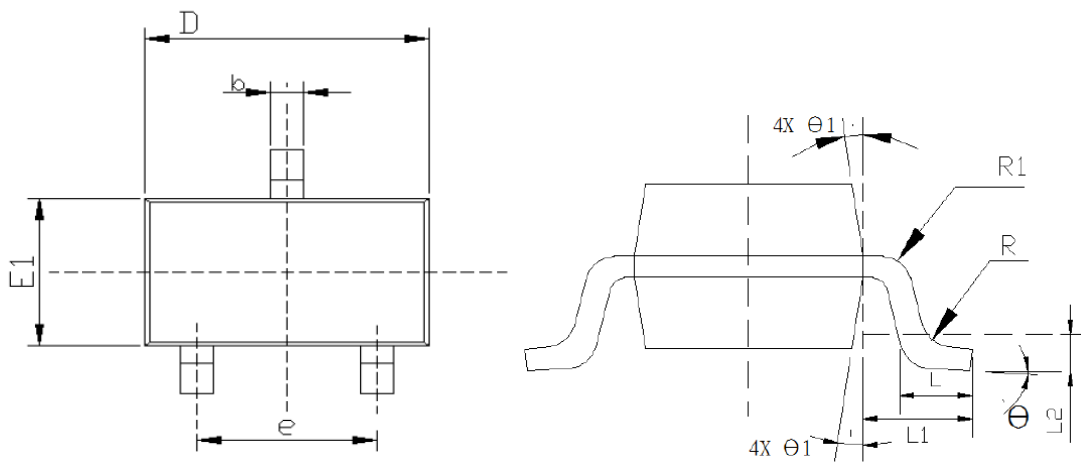

Common Dimensions (Units of Measure=Millimeter)			
SYMBOL	MINIMUM	NOMINAL	MAXIMUM
A	-	-	1.35
A1	0	-	0.15
A2	1.00	1.10	1.20
b	0.35	-	0.45
b1	0.32	-	0.38
c	0.14	-	0.20
c1	0.14	0.15	0.16
D	2.82	2.92	3.02
E	2.60	2.80	3.00
E1	1.526	1.626	1.726
e	0.90	0.95	1.00
e1	1.80	1.90	2.00
L	0.35	0.45	0.60
L1	0.6 REF		
L2	0.25 REF		
R	0.10	-	-
R1	0.10	-	0.25
θ	0°	4°	8°
θ 1	5°	10°	15°

SOT23-3L





Tape and Reel

SOT23-5L

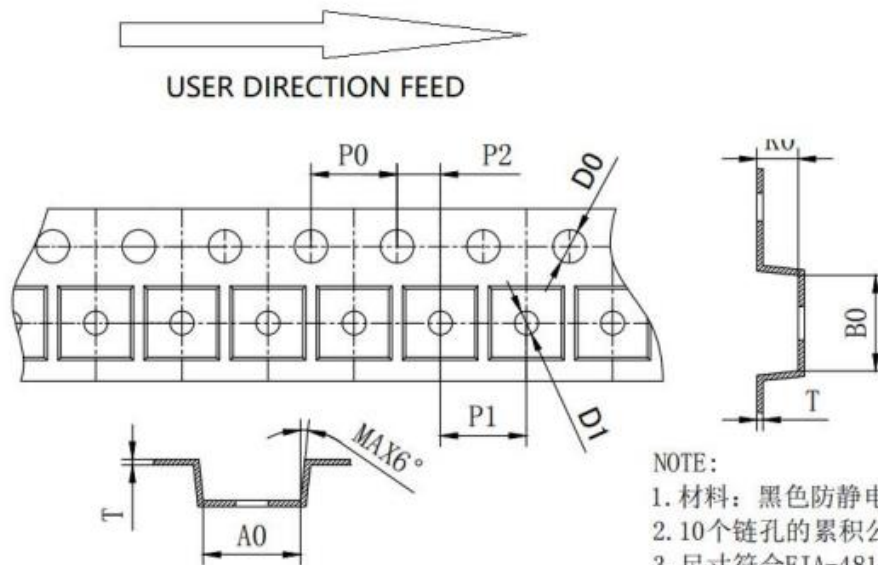
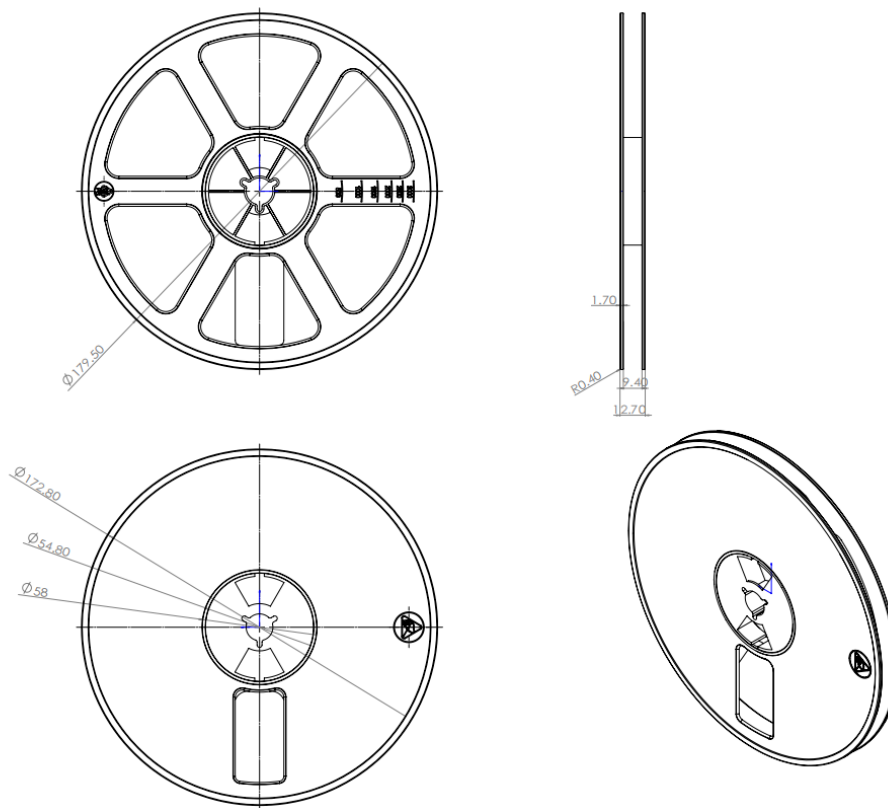

NOTE:

1. 材料：黑色防静电材料；
2. 10个链孔的累积公差不能超过 ± 0.2 ；
3. 尺寸符合EIA-481-E的要求。

SYMBOL	A0	B0	K0	P0	P1	P2
SPEC	3.30 ± 0.10	3.20 ± 0.10	1.50 ± 0.10	4.00 ± 0.10	4.00 ± 0.10	2.00 ± 0.05
SYMBOL	T	E	F	D0	D1	W
SPEC	0.20 ± 0.05	1.75 ± 0.10	3.50 ± 0.05	1.55 ± 0.05	$1.10^{+0.10}_{-0}$	$8.00^{+0.2}_{0.1}$

DFN1X1-4L

TAPE AND REEL INFORMATION

REEL DIMENSIONS

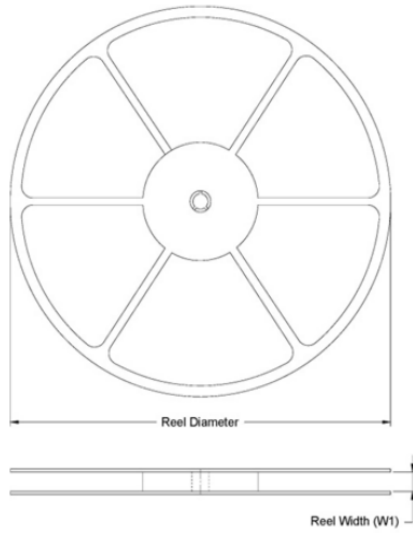

TAPE DIMENSIONS

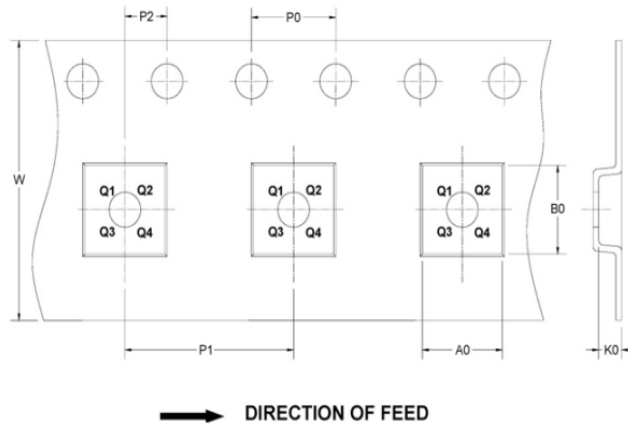

KEY PARAMETER LIST OF TAPE AND REEL

Device Name	Package Type	Reel Diameter	Unit: mm								Pin 1 Quadrant	Reel Q'ty
			Reel Width W1	A0	B0	K0	P0	P1	P2	W		
AF6219	DFN1*1	178	8	1.25	1.25	0.57	4	2	2	8	Q1	10000

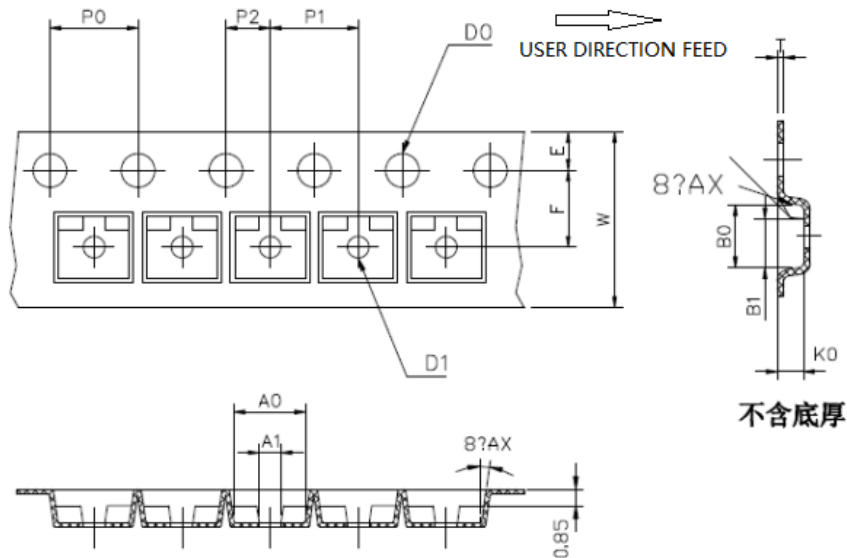
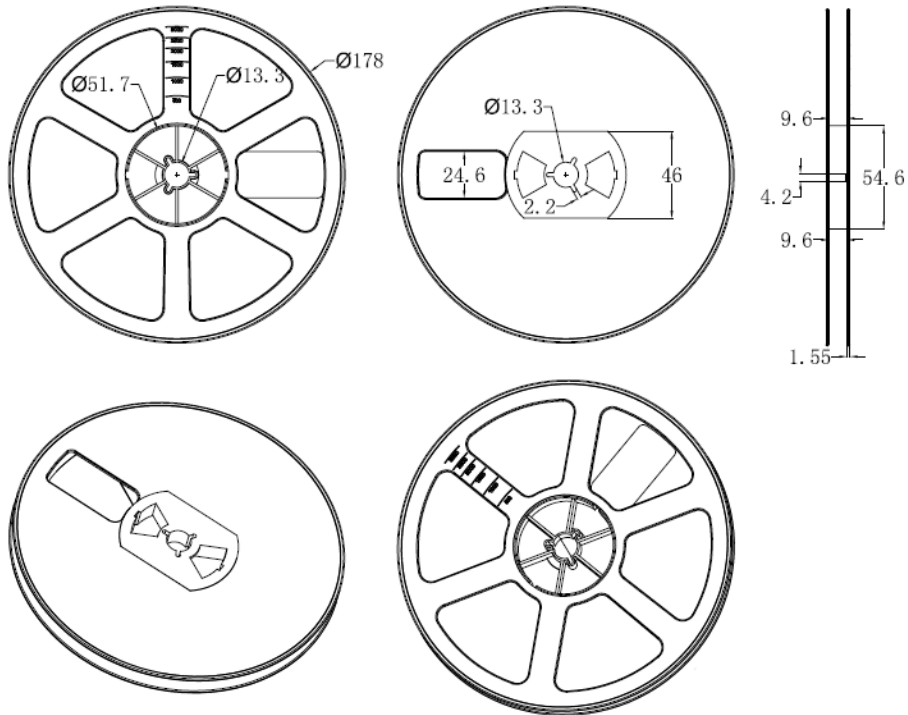
SOT23-3L

Symbol	A0	A1	B0	B1	K0	D ₀	D ₁	P ₀	P ₁
Spec	3.15±0.10	1.15±0.10	2.80±0.10	2.15±0.10	1.30±0.10	1.55±0.10	1.10±0.10	4.00±0.10	4.00±0.10
Symbol	W	E	F	P ₂	t	t1	10*P0	4-P0	
Spec	7.95±0.05	1.70±0.05	3.50±0.10	2.00±0.10	0.21±0.02	0.05以上	40.00±0.10	4.00±0.10	

NOTE:

- 1.材料: PC+PS导电
- 2.10个链孔的累积公差不能超过0.2MM;
- 3.250MM带子的扇形不得超过1MM;
- 4.按照EIA-481-D的要求。



Order Information

AF6219-XXC/M/D series

Voltage	DFN1X1-4L	Marking	Shipping	SOT23-5L	Marking	Shipping
1.2	√	1v2	Tape and Reel, 10K	√	1912	Tape and Reel, 3K
1.5		1v5		√	1915	
1.8	√	1v8		√	1918	
2.5	√	2v5		√	1925	
2.8	√	2v8		√	1928	
3.0	√	3v0		√	1930	
3.3	√	3v3		√	1933	
5.0	√	5v0			1950	

Voltage				SOT23-3L	Marking	Shipping
1.8				√	1918	Tape and Reel, 3K
2.5				√	1925	Tape and Reel, 3K
3.3				√	1933	Tape and Reel, 3K

AF6219N-XXC/M series

Voltage				SOT23-5L	Marking	Shipping
1.2				√	19N12	Tape and Reel, 3K
1.5					19N15	
1.8					19N18	
2.5				√	19N25	
2.8				√	19N28	
3.3				√	19N33	

Voltage				SOT23-3L	Marking	Shipping
36				√	19N36	Tape and Reel, 3K

History Version

V1.0	Product datasheet	2021-12-24
V1.1	Increase SOT23-3L package information	2022-03-09
V1.2	Update AF6219N information	2022-07-15
V1.3	Update Order Information	2022-11-10
V1.4	Update Electronics Characteristics	2023-05-30



DISCLAIMER

AFSEMI RESERVES THE RIGHT TO MAKE CHANGES WITHOUT FURTHER NOTICE TO ANY PRODUCTS HEREIN TO IMPROVE RELIABILITY, FUNCTION OR DESIGN. AFSEMI DOES NOT ASSUME ANY LIABILITY ARISING OUT OF THE APPLICATION OR USE OF ANY PRODUCT OR CIRCUIT DESCRIBED HEREIN; NEITHER DOES IT CONVEY ANY LICIENCE UNDER ITS PATENT RIGHTS, NOR THE RIGHTS OF OTHERS.

THE GRAPHS PROVIDED IN THIS DOCUMENT ARE STATISTICAL SUMMARIES BASED ON A LIMITED NUMBER OF SAMPLES AND ARE PROVIDED FOR INFORMATIONAL PURPOSE ONLY. THE PERFORMANCE CHARACTERISTICS LISTED IN THEM ARE NOT TESTED OR GUARANTEED. IN SOME GRAPHS, THE DATA PRESENTED MAY BE OUTSIDE THE SPECIFIED OPERATING RANGE (E.G. OUTSIDE SPECIFIED POWER SUPPLY RANGE) AND THEREFORE OUTSIDE THE WARRANTED RANGE.