



## SSC8L60GT6

### N-Channel Enhancement Mode MOSFET

#### ➤ Features

V <sub>DS</sub>	V <sub>GS</sub>	R <sub>DS(ON)</sub> Typ.	I <sub>D</sub>
60V	±20V	2 mΩ@10V	164A
		2.9mΩ@4.5V	

#### ➤ Description

This device is N-Channel enhancement MOSFET. Uses SGT technology and design to provide excellent RDSON with low gate charge. This device is suitable for use in DC-DC conversion, power switch and charging circuit.

**100% UIS + ΔVDS + Rg Tested!**

#### ➤ Applications

- Motor Drive Control
- Portable Devices
- DCDC Conversion
- Power Supplies
- Synchronous Rectification

#### ➤ Ordering Information

Device	Package	Shipping
SSC8L60GT6	TO-263-3L	800/Reel

#### ➤ Pin Configuration

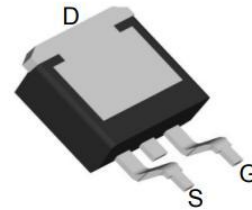

**TO-263-3L (Bottom View)**

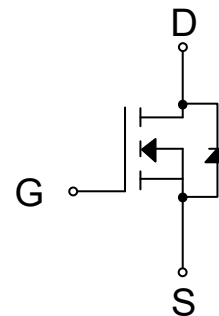

**Pin Configuration**

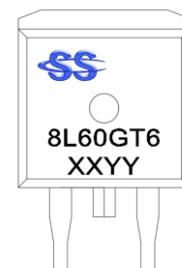

**Marking**

(XXYY: Internal Traceability Code)



## ➤ Absolute Maximum Ratings (T<sub>A</sub>=25°C unless otherwise noted)

Symbol	Parameter	Ratings	Unit
V <sub>DSS</sub>	Drain-to-Source Voltage	60	V
V <sub>GSS</sub>	Gate-to-Source Voltage	±20	V
I <sub>D</sub>	Continuous Drain Current <sup>d</sup>	T <sub>C</sub> =25°C	164
		T <sub>C</sub> =100°C	103
I <sub>DSM</sub>	Continuous Drain Current <sup>a</sup>	T <sub>A</sub> =25°C	27
		T <sub>A</sub> =70°C	17
I <sub>DM</sub>	Pulsed Drain Current <sup>b</sup>	656	A
P <sub>D</sub>	Power Dissipation <sup>c</sup>	T <sub>C</sub> =25°C	125
		T <sub>C</sub> =100°C	50
P <sub>DSM</sub>	Power Dissipation <sup>a</sup>	T <sub>A</sub> =25°C	3.5
		T <sub>A</sub> =70°C	1.4
I <sub>AS</sub>	Avalanche Current <sup>b</sup> L=0.5mH Single Pulse	32	A
E <sub>AS</sub>	Avalanche Energy <sup>b</sup> L=0.5mH Single Pulse	256	mJ
T <sub>J</sub>	Operation junction temperature	-55~150	°C
T <sub>STG</sub>	Storage temperature range	-55~150	

## ➤ Thermal Resistance Ratings (T<sub>A</sub>=25°C unless otherwise noted)

Symbol	Parameter	Ratings		Unit
R <sub>θJA</sub>	Junction-to-Ambient Thermal Resistance <sup>a</sup>	26	35	°C/W
R <sub>θJC</sub>	Junction-to-Case Thermal Resistance	0.7	1.0	

Note:

- The value of R<sub>θJA</sub> is measured with the device mounted on 1 in<sup>2</sup> FR-4 board with 2oz.copper, in a still air environment with T<sub>A</sub>=25°C. The value in any given application depends on the user is specific board design. The power dissipation is based on the t≤10s thermal resistance rating.
- Repetitive rating, pulse width limited by junction temperature.
- The power dissipation P<sub>D</sub> is based on T<sub>J(MAX)</sub>=150°C, using junction-to-case thermal resistance, and is more useful in setting the upper dissipation limit for cases where additional heat sinking is used.
- The maximum current rating is package limited.



➤ **Electrical Characteristics (T<sub>A</sub>=25°C unless otherwise noted)**

Parameter	Symbol	Test Conditions	Min.	Typ.	Max.	Unit
Drain-Source Breakdown Voltage	V <sub>(BR)DSS</sub>	V <sub>GS</sub> = 0V, I <sub>D</sub> = 250μA	60			V
Gate Threshold Voltage	V <sub>GS(th)</sub>	V <sub>DS</sub> = V <sub>GS</sub> , I <sub>D</sub> = 250uA	1	1.7	2.5	V
Drain-Source On-Resistance	R <sub>DS(on)</sub>	V <sub>GS</sub> = 10V, I <sub>D</sub> = 20A		2	2.9	mΩ
Drain-Source On-Resistance	R <sub>DS(on)</sub>	V <sub>GS</sub> = 4.5V, I <sub>D</sub> = 20A		2.9	3.9	mΩ
Zero Gate Voltage Drain Current	I <sub>DSS</sub>	V <sub>DS</sub> = 60V, V <sub>GS</sub> = 0V			1	μA
Gate-Source Leak Current	I <sub>GSS</sub>	V <sub>GS</sub> = ±20V, V <sub>DS</sub> = 0V			±100	nA
Transconductance	G <sub>FS</sub>	V <sub>DS</sub> = 5V, I <sub>D</sub> = 20A		30		s
Forward Voltage	V <sub>SD</sub>	V <sub>GS</sub> = 0V, I <sub>S</sub> = 10A		0.75	1.3	V
Input Capacitance	C <sub>ISS</sub>	V <sub>DS</sub> = 30V, V <sub>GS</sub> = 0V, f = 1MHz		4750		pF
Output Capacitance	C <sub>OSS</sub>			1208		
Reverse Transfer Capacitance	C <sub>RSS</sub>			32		
Total Gate Charge	Q <sub>G</sub>	V <sub>GS</sub> = 10V, V <sub>DS</sub> = 30V, I <sub>D</sub> = 20A		80		nC
Gate to Source Charge	Q <sub>GS</sub>			15		
Gate to Drain Charge	Q <sub>GD</sub>			12		
Turn-on Delay Time	T <sub>D(ON)</sub>	V <sub>GS</sub> = 10V, V <sub>DS</sub> = 30V, I <sub>D</sub> = 20A, R <sub>G</sub> = 1.5Ω		10		ns
Rise Time	T <sub>r</sub>			29		
Turn-off Delay Time	T <sub>D(OFF)</sub>			90		
Fall Time	T <sub>f</sub>			62		
Diode Recovery Time	T <sub>rr</sub>	I <sub>F</sub> =20A, di/dt=500A/us		60		ns
Diode Recovery Charge	Q <sub>rr</sub>	I <sub>F</sub> =20A, di/dt=500A/us		272		nC



## Typical Performance Characteristics ( $T_A=25^\circ\text{C}$ unless otherwise noted)

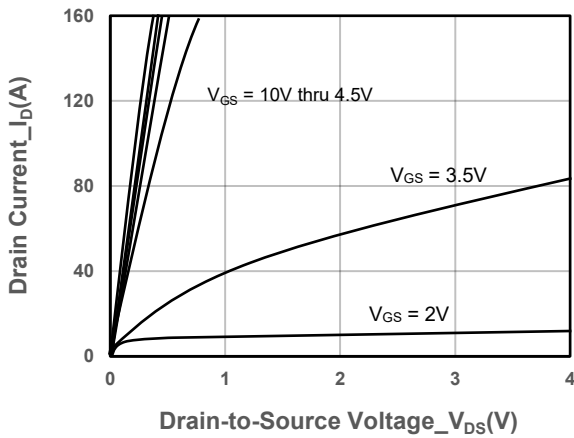

Output Characteristics

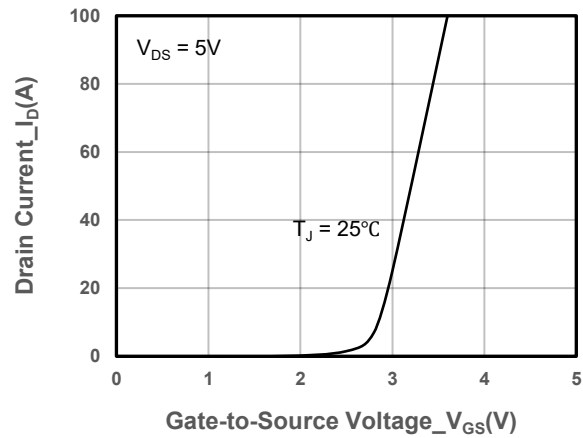

Transfer Characteristics

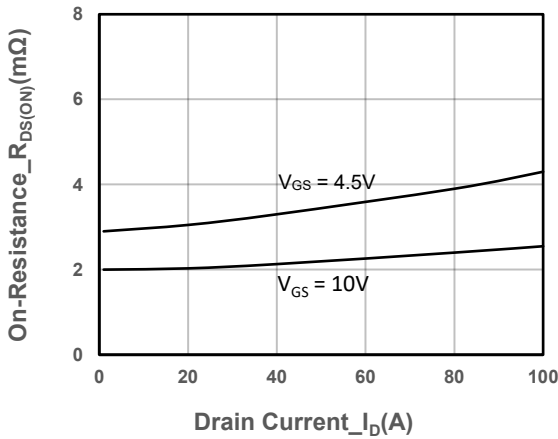

On-Resistance vs. Drain Current and Gate Voltage

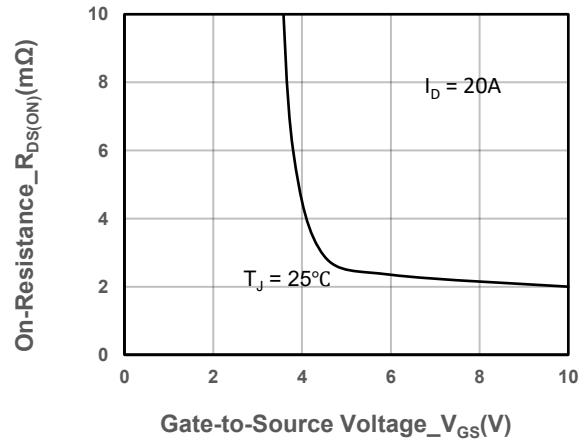

On-Resistance vs. Gate-to-Source Voltage

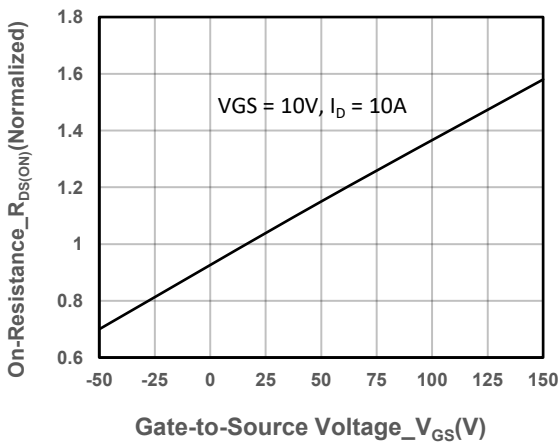

On-Resistance vs. Junction Temperature

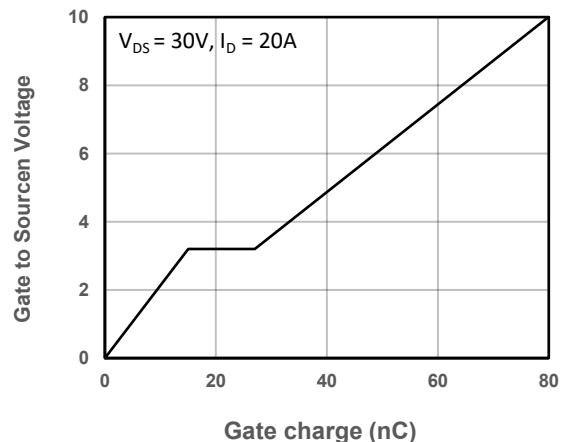

Gate-Source Voltage vs. Gate charge

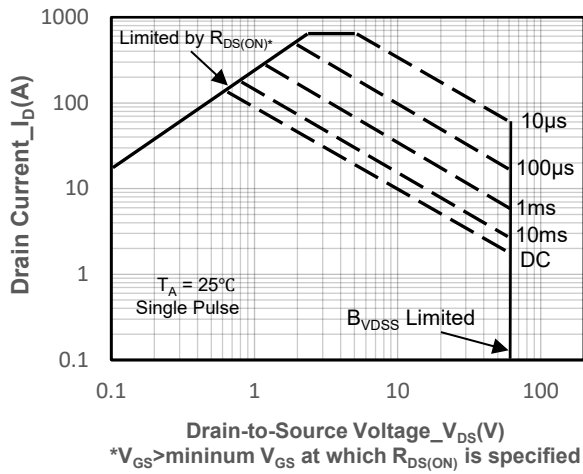

## Safe Operating Area vs. Junction-to-Ambient

## ➤ Package Information

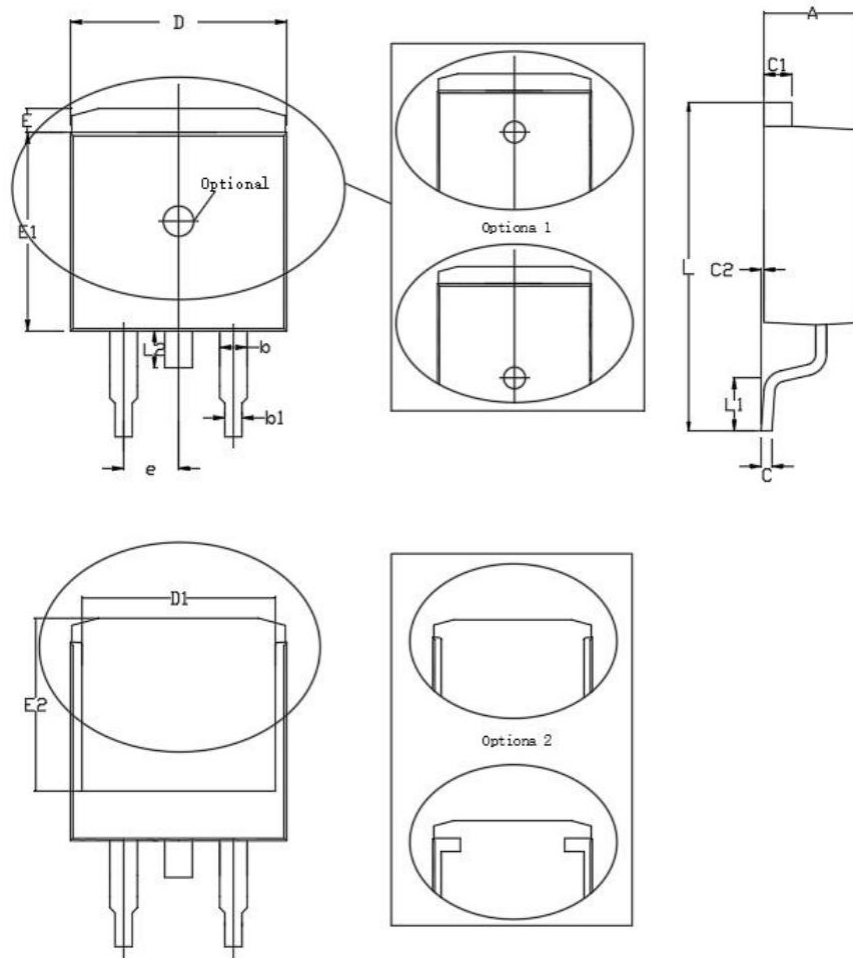

Symbol	MILL IMETER			Symbol	MILL IMETER		
	Min	Nom	Max		Min	Nom	Max
A	4.40	4.55	4.70	E	1.02	1.27	1.67
b	1.17	1.28	1.37	E1	8.38	9.15	9.65
b1	0.51	0.80	0.91	E2	6.85	8.00	8.40
C	0.38	0.47	0.74	e	2.54BSC		
C1	1.14	1.30	1.65	L	14.61	15.24	15.88
C2	0.02	0.10	0.20	L1	1.50	/	2.60
D	9.65	10.00	10.70	L2	1.30	1.50	1.75
D1	6.25	7.40	8.37				



## DISCLAIMER

SSCSEMI RESERVES THE RIGHT TO MAKE CHANGES WITHOUT FURTHER NOTICE TO ANY PRODUCTS HEREIN TO IMPROVE RELIABILITY, FUNCTION OR DESIGN. SSCSEMI DOES NOT ASSUME ANY LIABILITY ARISING OUT OF THE APPLICATION OR USE OF ANY PRODUCT OR CIRCUIT DESCRIBED HEREIN; NEITHER DOES IT CONVEY ANY LICIENCE UNDER ITS PATENT RIGHTS, NOR THE RIGHTS OF OTHERS.

THE GRAPHS PROVIDED IN THIS DOCUMENT ARE STATISTICAL SUMMARIES BASED ON A LIMITED NUMBER OF SAMPLES AND ARE PROVIDED FOR INFORMATIONAL PURPOSE ONLY. THE PERFORMANCE CHARACTERISTICS LISTED IN THEM ARE NOT TESTED OR GUARANTEED. IN SOME GRAPHS, THE DATA PRESENTED MAY BE OUTSIDE THE SPECIFIED OPERATING RANGE (E.G. OUTSIDE SPECIFIED POWER SUPPLY RANGE) AND THEREFORE OUTSIDE THE WARRANTED RANGE.

OUR PRODUCT SPECIFICATIONS ARE ONLY VALID IF OBTAINED THROUGH THE COMPANY'S OFFICIAL WEBSITE, CRM SYSTEM, OR OUR SALES PERSONNEL CHANNELS. IF CHANGES OR SPECIAL VERSIONS ARE INVOLVED, THEY MUST BE STAMPED WITH A QUALITY SEAL AND MARKED WITH A SPECIAL VERSION NUMBER TO BE VALID.