



SSCFUS1ADA THRU SSCFUS1MDA

1.0Amp Ultra Fast Recovery Surface Mounted Rectifiers

● Features

- ✧ The plastic package carries Underwriters Laboratory Flammability Classification 94V-0
- ✧ Construction utilizes void-free molded plastic technique
- ✧ Low reverse leakage
- ✧ High forward surge current capability
- ✧ High temperature soldering guaranteed 260°C/10 seconds at terminals

● PIN configuration



SMA/DO-214AC



Circuit Diagram

● Mechanical Data

- ✧ Case: Molded plastic body
- ✧ Terminals: Solder plated, solderable per MIL-STD-750, Method 2026
- ✧ Polarity: Polarity symbol marking on body
- ✧ Mounting Position: Any



Marking

(US1D: SSCFUS1DDA Marking Code)

● Absolute Maximum Rating @T_A=25°C

Parameter	Symbol	US							Unit
		1A	1B	1D	1G	1J	1K	1M	
Maximum Peak Repetitive Peak Reverse Voltage	V _{RRM}	50	100	200	400	600	800	1000	V
Maximum RMS Voltage	V _{RMS}	35	70	140	280	420	560	700	V
Maximum DC Blocking Voltage	V _{DC}	50	100	200	400	600	800	1000	V
Maximum Average Forward Rectified Current	I _{F(AV)}	1.0							A
Non-repetitive Peak Forward Surge Current @t=8.3ms	I _{FSM}	30.0							A
Max Instantaneous Forward Voltage at 1.0A	V _F	1.0			1.4	1.7			V
Maximum DC Reverse Current Ta = 25 °C at Rated DC Blocking Voltage Ta =100 °C	I _R				2.0				μA
					200				
Maximum Reverse Recovery Time (Note 1)	T _{rr}	50				75			ns
Typical Junction Capacitance (Note 2)	C _J	20.0							pF
Typical Thermal Resistance	R _{qJA}	80.0							°C/W
Operating Temperature and Storage Temperature	T _J , T _{STG}	-55 ~ +150							°C

Note: 1. Reverse recovery time test condition: IF=0.5A IR=1.0A Irr=0.25A

2. Measured at 1MHz and applied reverse voltage of 4.0V DC.



- Typical Performance Characteristics

FIG. 1- DERATING CURVE OUTPUT RECTIFIED CURRENT

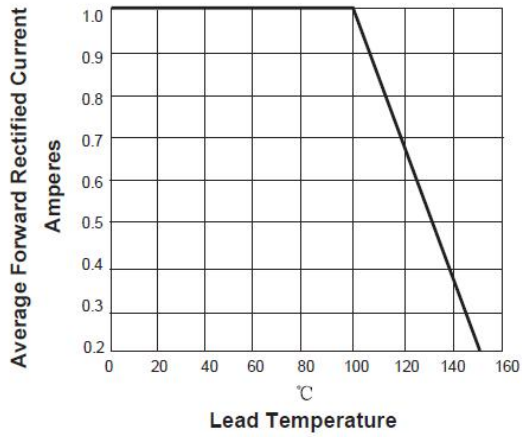

FIG. 2-MAXIMUM NON-REPETITIVE PEAK FORWARD SURGE CURRENT PER LEG

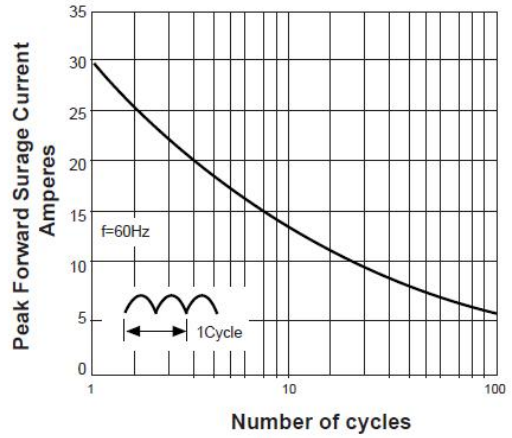

FIG. 3-TYPICAL FORWARD VOLTAGE CHARACTERISTICS

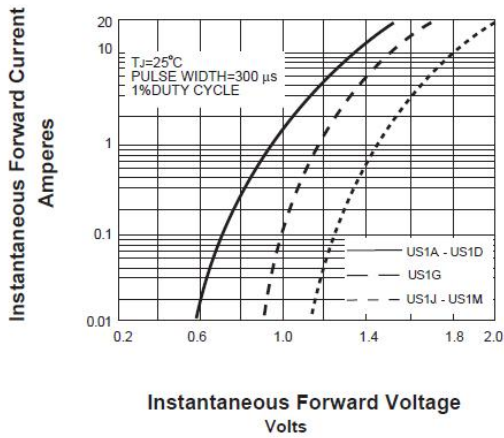
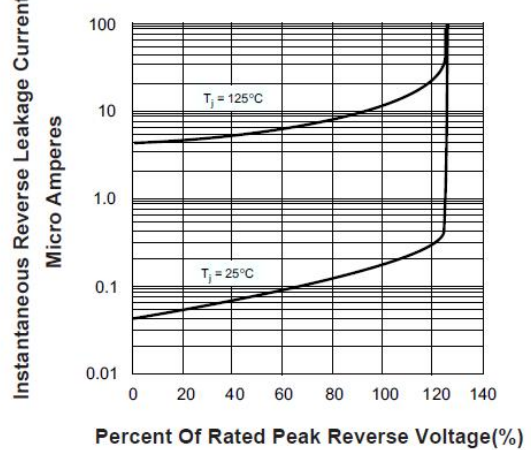

FIG. 4-TYPICAL REVERSE LEAKAGE CHARACTERISTICS





● Package Information

Ordering Information

Device	Package	Marking	Qty per Reel	Reel Size
SSCFUS1ADA	SMA/DO-214AC	US1A	7500	11 Inch
SSCFUS1BDA	SMA/DO-214AC	US1B	7500	11 Inch
SSCFUS1DDA	SMA/DO-214AC	US1D	7500	11 Inch
SSCFUS1GDA	SMA/DO-214AC	US1G	7500	11 Inch
SSCFUS1JDA	SMA/DO-214AC	US1J	7500	11 Inch
SSCFUS1KDA	SMA/DO-214AC	US1K	7500	11 Inch
SSCFUS1MDA	SMA/DO-214AC	US1M	7500	11 Inch

Mechanical Data

Case: SMA/DO-214AC

Case Material: Molded Plastic. UL Flammability

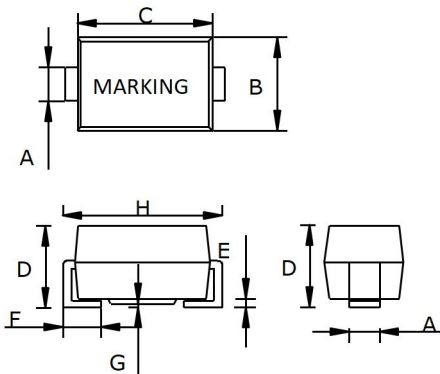

DIM	Millimeters		
	Min	Nom	Max
A	1.40	1.50	1.60
B	2.50	2.67	2.90
C	4.00	4.40	4.50
D	2.00	2.25	2.45
E	0.05	0.200	0.203
F	0.76	1.14	1.52
G	-	-	0.203
H	4.90	5.0	5.30

Recommended Pad outline (Unit: mm)

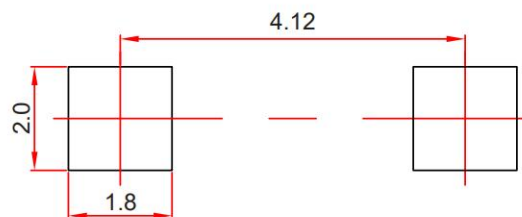



DISCLAIMER

SSCSEMI RESERVES THE RIGHT TO MAKE CHANGES WITHOUT FURTHER NOTICE TO ANY PRODUCTS HEREIN TO IMPROVE RELIABILITY, FUNCTION OR DESIGN. SSCSEMI DOES NOT ASSUME ANY LIABILITY ARISING OUT OF THE APPLICATION OR USE OF ANY PRODUCT OR CIRCUIT DESCRIBED HEREIN; NEITHER DOES IT CONVEY ANY LICIENCE UNDER ITS PATENT RIGHTS, NOR THE RIGHTS OF OTHERS.

THE GRAPHS PROVIDED IN THIS DOCUMENT ARE STATISTICAL SUMMARIES BASED ON A LIMITED NUMBER OF SAMPLES AND ARE PROVIDED FOR INFORMATIONAL PURPOSE ONLY. THE PERFORMANCE CHARACTERISTICS LISTED IN THEM ARE NOT TESTED OR GUARANTEED. IN SOME GRAPHS, THE DATA PRESENTED MAY BE OUTSIDE THE SPECIFIED OPERATING RANGE (E.G., OUTSIDE SPECIFIED POWER SUPPLY RANGE) AND THEREFORE OUTSIDE THE WARRANTED RANGE.

OUR PRODUCT SPECIFICATIONS ARE ONLY VALID IF OBTAINED THROUGH THE COMPANY'S OFFICIAL WEBSITE, CRM SYSTEM, OR OUR SALES PERSONNEL CHANNELS. IF CHANGES OR SPECIAL VERSIONS ARE INVOLVED, THEY MUST BE STAMPED WITH A QUALITY SEAL AND MARKED WITH A SPECIAL VERSION NUMBER TO BE VALID.